

Model K2/SC™ Long-Distance Microscope System

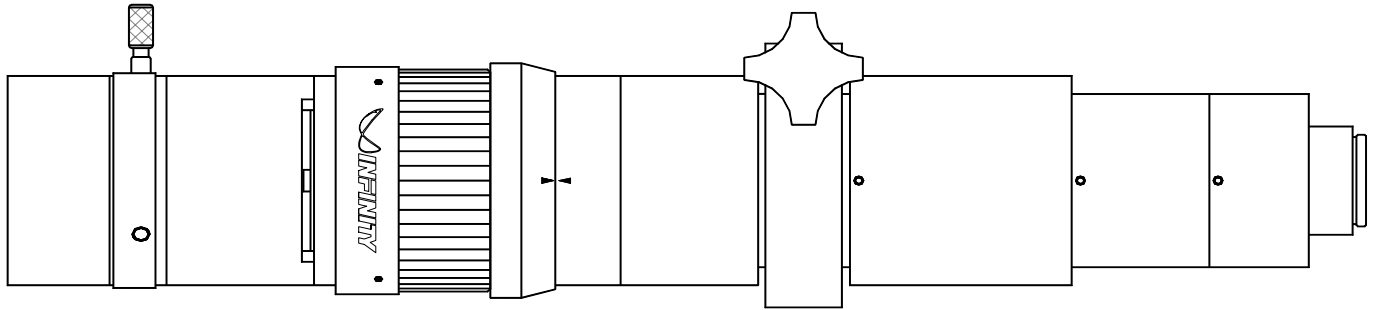

Model K2/SC Long-Distance Microscope

INTRODUCTION

The K2/SC is the latest model of the K2 Long-Distance Microscope series. It offers the finest imagery of any long-distance microscope ever produced. Its new AVS-2 internal focusing system (patents pending) provides spherical and chromatic correction previously thought impossible to attain. At the same time, the AVS-2 system expands the diffraction-limited field to over 43mm (diagonal) as opposed to competitive instruments which can only claim 12mm. Consequently, the K2/SC is not limited to c.2/3-in. formats. Rather, it can be used with photo and digital SLRs with sensors up to the 35mm format (24x36mm) with exceptional clarity and resolution throughout the field. Its contrast levels are higher than all other competitive instruments, providing usable—rather than merely theoretical—resolution that is artifact-free (no "doughnuts with out-of-focus details that can affect measurements and data). All-in-all, the K2/SC represents the ultimate in long-distance microscopy—and more. A single K2/SC can be equipped to function from infinity to the very limits of optical microscopy.

Note: The K2/SC magnifications are now shown without *any* amplifiers presumed in-system. Actually, the K2/SC can be amplified for magnifications higher than any previous models.

Please refer to the accompanying drawings for configuration details. The configurations are specific for optical quality and should not be altered in any way from their approved positions. When video/photo adapters are used in direct macro mode, the M62 Eyepiece Holder must not be used. **DO NOT ATTEMPT TO USE THE M62 EYEPIECE HOLDER AS AN EXTENSION TUBE, BECAUSE THE UNOCCUPIED SMOOTH EYEPIECE BORE WILL NOT ONLY THROW THE K2/S' TUBELENGTH/CORRECTIONS OFF, IT WILL ALSO PRODUCE INTENSE GLARE AND REFLECTION, DESTROYING IMAGE QUALITY.** The K2/SC's unique design and internal focusing system make traditional "conventional wisdom" regarding extension tube use obsolete. If you think that some special requirement could be served by tube extension, please contact us for suggestions. Unauthorized use of the K2/SC can void its warranty.

CONTROLS

Besides the focusing ring, the K2/SC has a built-in iris diaphragm for depth of field and light attenuation control. The iris can be observed directly by removing the eyepiece and looking down the tube. Since each object has its best overall iris setting due to inherent glare or contrast requirements, you may wish to employ the standard rule in microscopy (known as "Nelson's 3/4-aperture Rule") by closing-down the aperture 3/4 of the field observed. Alternately, after some practice, the effect of the aperture on the object's image can be observed by a sudden "jump" in image quality (the so-called "oomph" position). Although it can be used full-open for highest theoretical resolving power, the K2/S—like all other compound microscopes—benefits from "Nelson's Rule."

CentriTel™

The K2/SC is a supplemental CentriTel optic. As such, its S58 tube can be replaced by the supplemental CentriTel Focuser, permitting focus to be adjusted from a fixed working distance and field of view without essential magnification change. This makes the K2/SC perfect for montaging and 3-D stacking. In addition, the CentriTel Focuser also acts as an extremely fine secondary focus adjustment, "peeling away" detail at various depths.

To mount the CentriTel Focuser, set the K2/SC focus as usual with the S-58 Tube in place with the T-36 tube behind it. Then using the Focus Ring Lock, lock the focus of the main body. Carefully remove the S-58 Tube from the system and replace it with the CentriTel Focuser. Keep the T-36 Tube in front of the CentriTel Focuser. Undo the setscrews on the CentriTel Focuser reference ring using the supplied #2-56 Allen wrench. Turn its focus adjustment to re-establish the former focus that was provided when the S58 tube was in place. Turn the reference ring to align the arrow markers and gently tighten its setscrews. Release the Main Focus by loosening the setscrews of the Focus Ring Lock.

It is now possible to use the Main Focus to set K2/SC to any of its working distances. The data will remain as when the S58 was in place, provided the CentriTel Focuser is set arrows-opposite as the Main Focus is used. Then, turning the CentriTel Focuser's adjustment will translate focus from the chosen fixed position and working distance without essential magnification changes.

TWO MAIN BODY CONFIGURATIONS

In order to maximize the potentials of the K2/SC, care was taken to design matched amplifiers that account for the characteristics of the new AVS-2 internal focusing system (*twice the lens elements of AVS-1*). Two configurations are now possible which maximize imaging for different purposes.

1) S Lens in-system: The K2/SC maintains the S Lens technology from the previous Model K2/S. This means that when the S Lens is positioned inside, the K2/SC can focus from infinity down to c.675mm when the Standard Objective is used exclusively with it. Amplifiers exclusively suited for use when the S Lens is in-system are the 2x TX Tube (all formats up to 35mm), 2x DL Tube (C-mount only), the 1-2.2x Zoom Module—as well as the UNIPAR/Eyepiece system.

2) WITHOUT S Lens in-system: This is the most versatile K2/SC configuration. The S Lens is taken out (or not introduced) into the Main Body. An additional T36mm is placed after the S58 Tube or Mirror Diverter ports. This balances the image quality in conjunction with the AVS-2 internal focusing system. Then, the T36 can be removed and a CF Tube 1.66x parfocal amplifier put in its place. This 1.66x factor (rather than 2x) still covers the 35mm format and, in conjunction with the AVS-2 system, provides image quality maintained even to the edges of the field. The resolution thus captured is actually able to be enlarged MORE than when a 2x amplifier is used, since the 1.66x factor matches the pixel sizes of large format sensors more properly. Then, when the InFocus™ Microscope Objective Holder is used, it combines to produce the theoretically most-proficient large format magnification factor of 2.5x times the objective's rated power. The full imaging quality is maintained in strict accordance with the most demanding microscopical practices. In this configuration, the 2x DL Tube and 1-2.2x Zoom Module are also compatible.

THREE OPERATING RANGES

For two of the three K2/SC operating ranges, a Standard or CF-Series Objective is directly attached to its front dovetail. The third range is obtained by attaching the InFocus™ Microscope Objective Holder with an adapter for any infinity-corrected microscope objective made by Infinity Photo-Optical Achrovid™, Mitutoyo, Olympus, Nikon, Edmund or Edmund REFLX. Depending on the objective, the K2/SC can be used in transmitted or coaxial illumination (by interfacing the Coaxial Illuminator).

1) Standard (S) Infinity Range (infinity to c.675mm)

The Standard Infinity Range is the greatest offered from any long-distance microscope on the market today. For focus from infinity down to c.675mm, the Standard Objective is used in conjunction with the internally-positioned S Lens. The two lens systems work harmoniously as a matched system. This unique approach assures the finest imagery ever offered by any K2 model in the Standard Range of operation.

2) Close-Focus (CF) Range

By not utilizing the S Lens (which does not disturb the mounting of the K2/SC on a fixed stand or positioner), Standard and CF-Series Objectives can be used for progressive focus from 980mm (Standard Objective) down to 55mm (CF-4). Depending on the chosen objective, primary magnification ranges from 0.31x to 5.33x. Additional amplifiers permit these primary magnifications to be further enlarged.

3) High-Power Micro Mode

The K2/SC can also operate in the high-powered micro mode by simply attaching the InFocus™ Microscope Objective Holder and the appropriate adapter for infinity-corrected objectives: Achrovid™, Mitutoyo, Olympus,

Nikon, Edmund, Edmund REFLX™, etc. Whether in coaxial/epi- or transmitted illumination, these K2/SC accessories permit it to achieve high magnifications—literally to the potential *limits of optical microscopy*—focused either manually or by motor-control.

APPLICATION-SPECIFIC REAR TUBE LENGTHS

Three specific tube lengths complement the three operating ranges of the K2/SC. By carefully matching the optical tube length to the application, the most stringent corrections are obtained for aberrations, spherical and chromatic (SC) in particular.

1) S Range

When the S Lens is in-system, NO rear spacers are used. For 2x amplification, the TX Tube is properly corrected to interface the S58 Tube and all other rear accessories. The DL Tube interfaces C-mount and camera.

2) CF Range

When the Standard and CF-series objectives are used, a T36 spacer is positioned after the S58 tube or Mirror Diverter. When the CF Tube 1.66x amplifier is employed, it is exchanged with the T36 tube and the CF Tube's bottom T24 tube is kept in-system. The Zoom Module is positioned after the T36 spacer normally used. The DL Tube interfaces C-mount and camera.

3) High-Power Micro Mode

In order for the K2/SC to function properly with infinity-corrected microscope objectives, it must utilize the InFocus Microscope Objective holder on its front (IMOH). The IMOH has a special lens in it which sets the K2/SC for InFocus™ internal focusing. When the IMOH is used, a T18 spacer (supplied with the IMOH) *REPLACES* the T36 spacer used with the CF Range. Likewise, the CF Tube is replaced by removing the T24 spacer used with the CF Range and substituting the T7.2 spacer (supplied with each IMOH).

Please take care to use these specific tube lengths as the applications demand. In this way, the K2/SC's finest imagery is obtained.

AMPLIFIERS

The K2/SC Main Bodies are supplied *without* amplifying optics. All amplifiers are **MATCHED MULTIPLIERS**, specific to either of the K2/SC's two configurations.

Amplifiers for S Lens in-system include 2x TX Tube (all formats; camera mount required); 2x DL Tube (C-mount) and the 1-2.2x Zoom Module (Adjustable C-mount required). In addition, the UNIPAR may be used with eyepieces (requires M62 Eyepiece Holder and suitable camera mount).

Amplifiers used WITHOUT S Lens in-system include 1.66x CF Tube (all formats; camera mount required); 2x DL Tube (C-mount) and the 1-2.2x Zoom Module (Adjustable C-mount required). In addition, the UNIPAR may be used with eyepieces (requires M62 Eyepiece Holder and suitable camera mount).

Two different amplifiers can be combined for even greater magnifications. For example, a 2x DL Tube can supplement the Zoom Module (Adjustable C-Mount required to reset parfocality of zoom; the Zoom Module then functions 2x-4.4x). The 2 DL Tube and its lockable LDL version (however mixed) are the only amplifiers designed to be ganged with others of their own kind.

ILLUMINATION

The K2/SC functions best when the objective is as evenly and as brilliantly illuminated as possible. Intense lamps or fiber optic illuminators should be used. An adapter is available to mount 66mm fiber optic ring lights to the filter holders of all objectives except the CF-4. Flash (strobe) units provide excellent color characteristics.

STANDS

The K2/SC can be mounted on any heavy-duty video-type floor-standing tripod or jig which can secure it either by standard 1/4-20 screws or M4 screws (mounted outboard on the K2/SC's mounting clamp). In addition, INFINITY manufactures adapters for major-brands of "boom-type" stereomicroscope stands [e.g., Olympus, Nikon, Unitron, etc.].

FURTHER POSSIBILITIES

The K2/SC is part of a comprehensive line of instruments made by INFINITY. As such, it is possible to mate many accessories for special purposes. Motor drives are available for focus, zoom—or both—controlled simply, by computer interface or by an autofocus module. Please do not hesitate to contact us with potential uses/configurations, since we have extensive experience in special-model configurations.

ACCESSORY WEIGHT

The K2/SC should not be abused with extra-heavy, unsupported weights. The greatest weight that should ever be placed directly on a port is 1-1.5 kilograms. Beyond that, heavy cameras should be supported independently. We will be pleased to advise.

CARE AND CLEANING

The K2/SC should be treated as the fine optical instrument that it is. Care should be taken to keep dust and dirt off external lens surfaces. The unit can be cleaned (metal parts only) by a cloth moistened with alcohol. The external optical surfaces should be cleaned only when necessary, and then, only by a soft cotton swab moistened by an approved optical glass cleaner. If you have further questions, please contact Infinity Photo-Optical Company or your authorized dealer.

Video Formats

Format	Factor	Diagram
1/4"	0.5	
1/3"	0.75	
1/2"	1.0	
2/3"	1.375	
1"	2.0	

Unless otherwise noted all data is given for 1/2" camera sensors. For FOV or magnification in other sensor sizes use the factors listed. For example, a FOV of 25mm listed for a 1/3" camera would be $25 \times 0.75 = 18.75\text{mm}$.

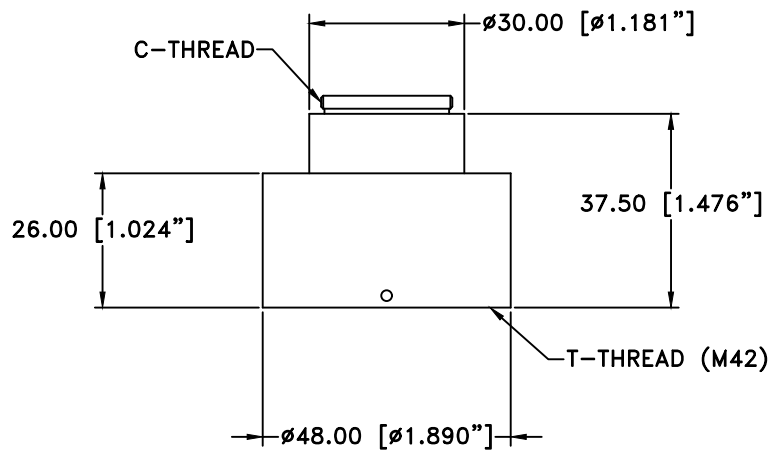

770507

C-MOUNT VIDEO ADAPTER

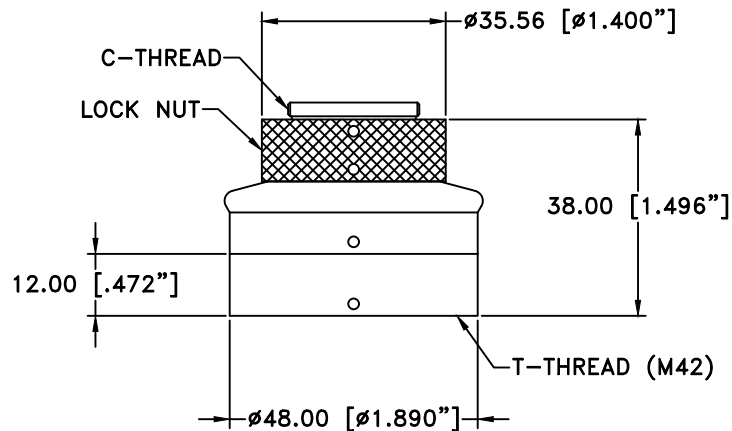

770511

STANDARD ROTATABLE C-MOUNT

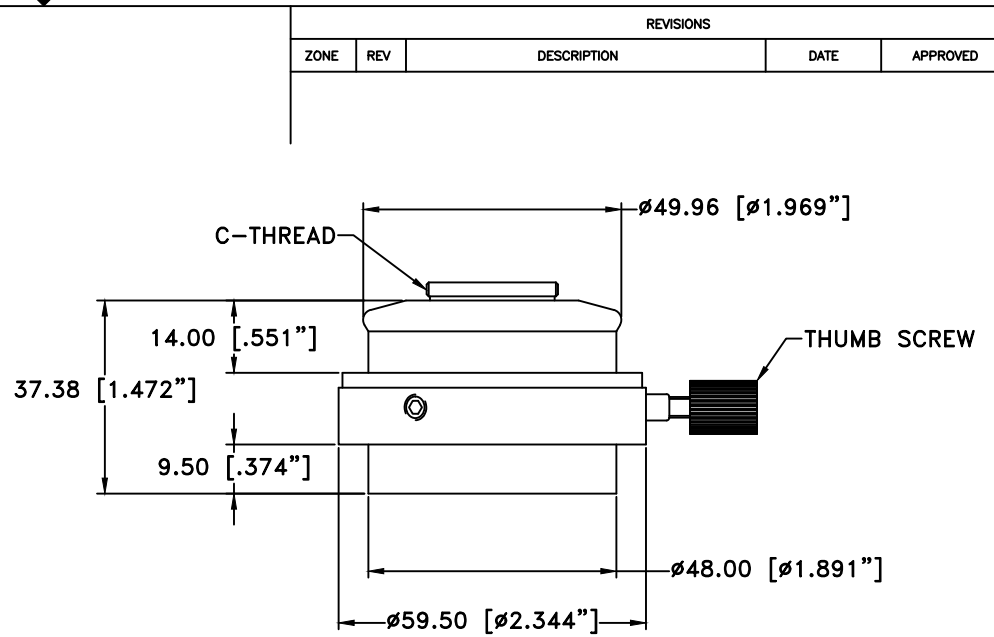

770509

ORIENTABLE C-MOUNT VIDEO ADAPTER

REVISIONS				
ZONE	REV	DESCRIPTION	DATE	APPROVED

This drawing is for informational purposes only.
No other rights or privileges are granted or implied.

THIS DRAWING IS THE PROPERTY OF THE INFINITY PHOTO-OPTICAL COMPANY AND IT MUST BE TREATED AS CONFIDENTIAL. SURFACE FINISH: OUTSIDE DIAMETERS FINISH IS CRITICAL. BEAD BLAST INTERNAL RETAINERS ALL DIMS. ARE IN mm [INCH]. DIMS. ARE AFTER ANODIZING TOL. DIAMETERS: ±0.025 [±0.001"] OTHERS: ±0.102 [±0.004"] UNIFIED THREADS ARE CLASS 2 METRIC THREADS ARE MEDIUM FIT BREAK ALL SHARP EDGES TO R0.25 [R0.010"]

INFINITY Photo-Optical Company
www.infinity-usa.com

C-MOUNT VIDEO ADAPTERS

Date: 10/30/17 MB	SIZE B	FSCM NO.	DWG NO.	REV -
Modified:	SCALE NONE	-	SHEET 1 OF 1	

MODEL K2/SC™ S LENS ASSEMBLY INSTRUCTIONS

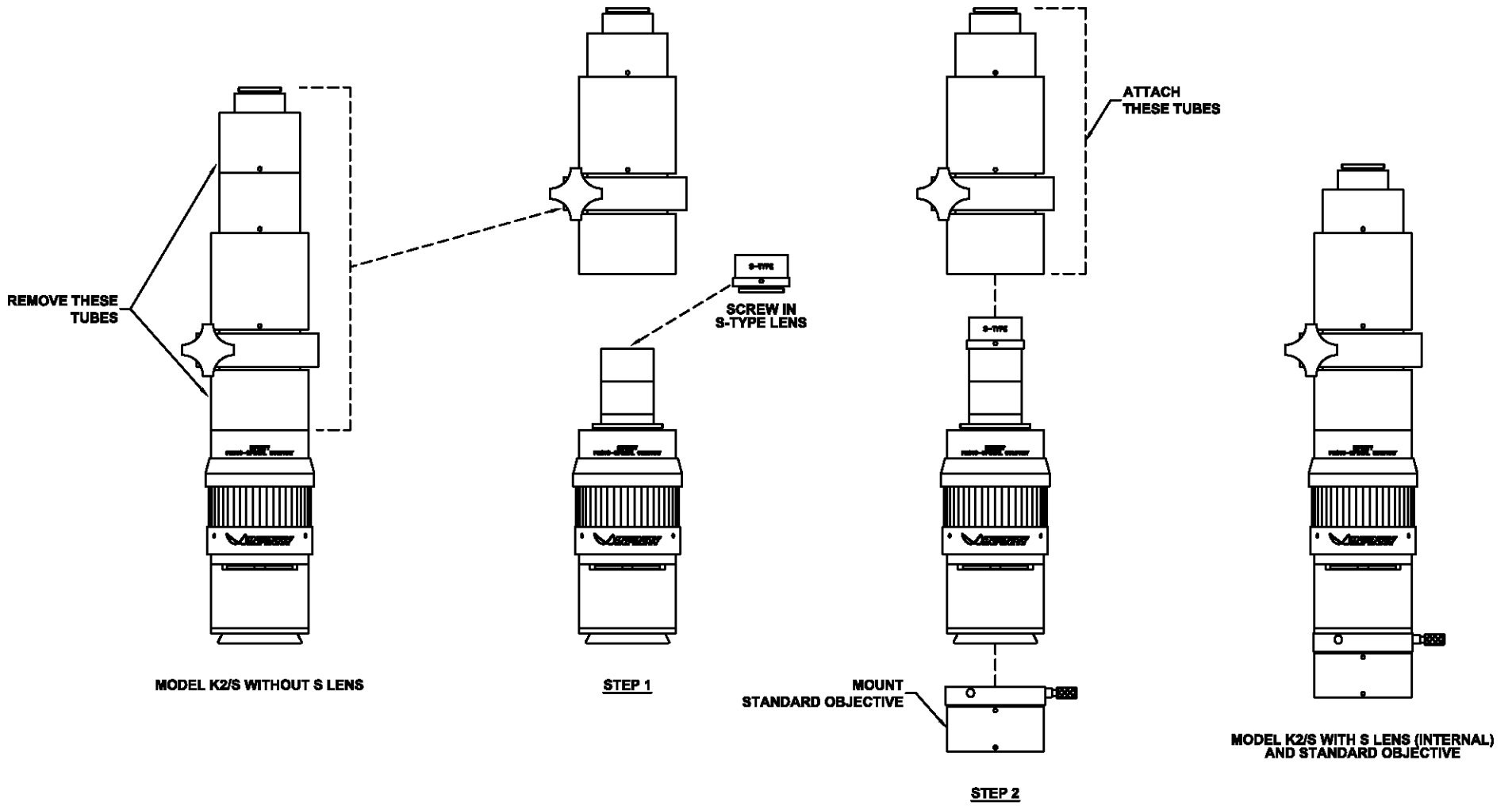

K2/SC OPTICAL DATA STANDARD OBJECTIVE WITH S LENS

WD mm	675	775	925	1175	1500	1900	2200	2500	3000
MAG	0.70	0.60	0.50	0.40	0.33	0.25	0.20	0.18	0.15
FOV mm	9.15	10.67	12.80	17.80	19.4	25.60	32.0	36.0	43.0

NOTE: The K2/SC has greater potential magnification than previous models.

The data above DO NOT assume amplifiers in-system.

*FOV based on 1/2" video format (6.4mm horizontally). See Video Format Page.

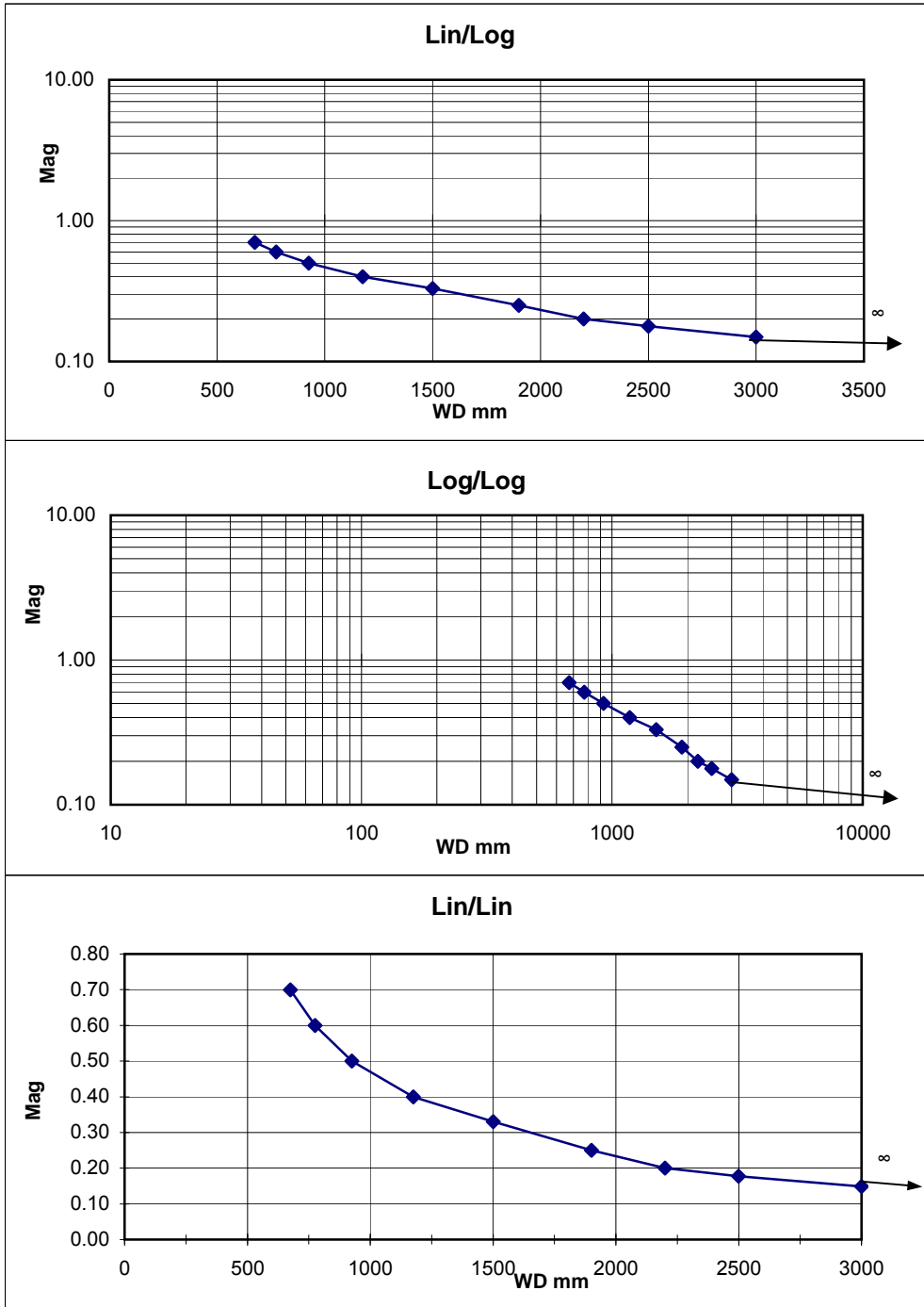

MODEL K2/SC OPTICAL RESOLUTION DATA STANDARD OBJECTIVE WITH S LENS

WDmm	675	775	925	1175	1500	1900	2200	2500	3000
MAG	0.70	0.60	0.50	0.40	0.33	0.25	0.20	0.18	0.15
NA	0.028	0.025	0.021	0.016	0.013	0.010	0.009	0.008	0.006
Resolution (lpmm)	84	74	62	49	38	30	26	23	19
Resolution (microns)	11.8	13.6	16.2	20.6	26.3	33.3	38.6	43.9	52.6
DOFmm	0.69	0.91	1.29	2.09	3.40	5.46	7.32	9.45	13.61

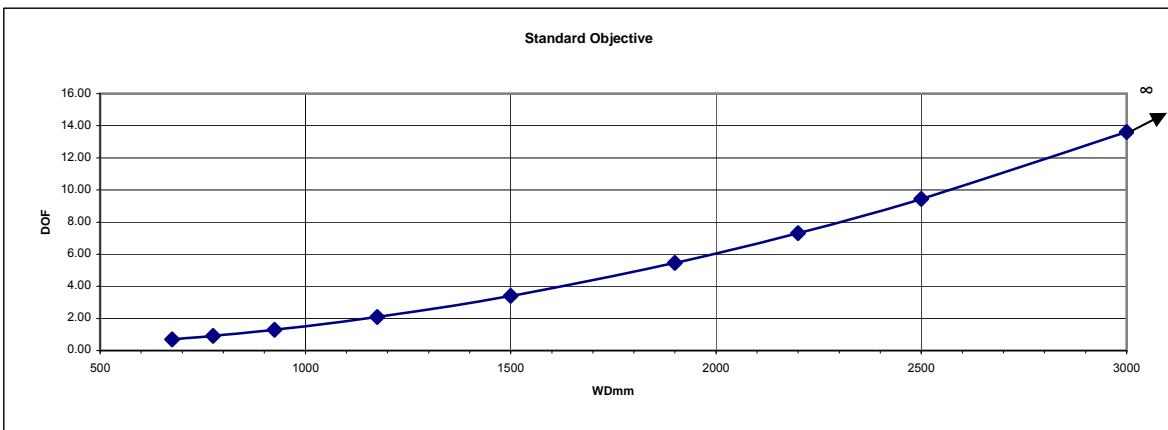
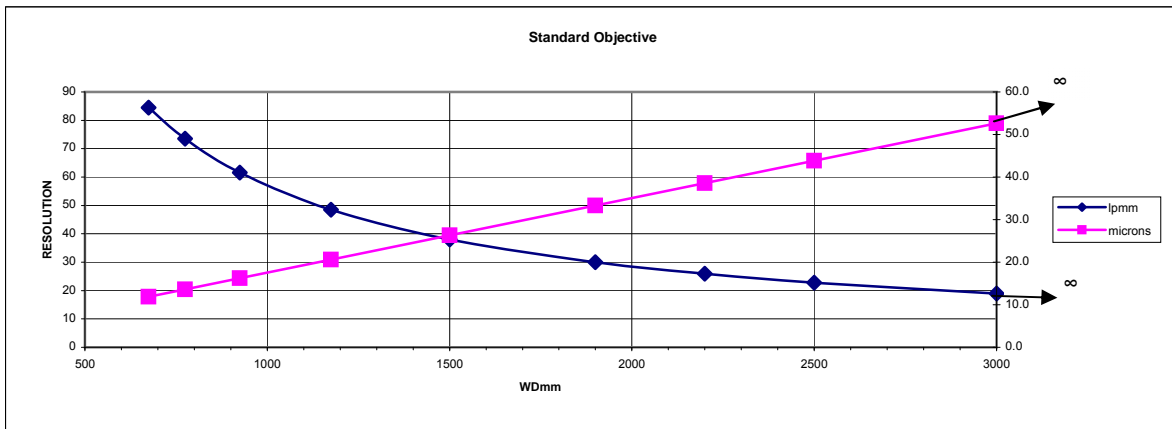
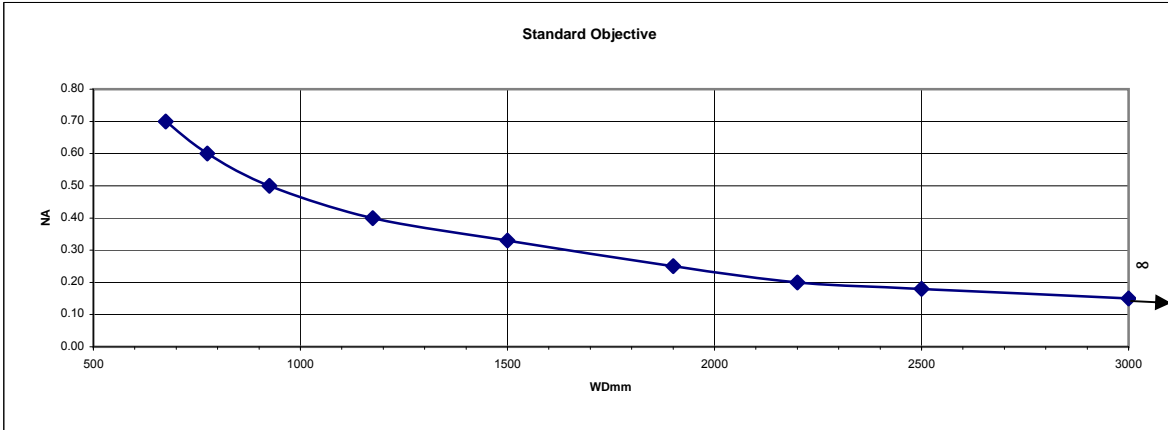

K2/SC OPTICAL DATA STANDARD AND CF-OBJECTIVES WITHOUT S LENS

K2/SC	STD w/o S Lens			CF-1			CF-1/B			CF-2			CF-3			CF-4		
	Near	Mid	Far	Near	Mid	Far	Near	Mid	Far	Near	Mid	Far	Near	Mid	Far	Near	Mid	Far
WD mm	360	510	980	265	365	580	222	290	418	138	190	205	92	105	125	55	60	63
MAG	0.95	0.64	0.31	1.28	0.86	0.52	1.4	1.07	0.71	2.29	1.52	1.36	3.05	2.56	2.06	5.33	4.74	4.27
FOV mm	6.74	10	20.5	5.0	7.4	12.2	4.6	6.00	9.0	2.80	4.20	4.7	2.10	2.50	3.1	1.20	1.35	1.50

NOTE: The K2/SC has greater potential magnification than previous models. The data above *DO NOT* assume amplifiers in-system.

*FOV based on 1/2" video format (6.4mm horizontally). See Video Format Page.

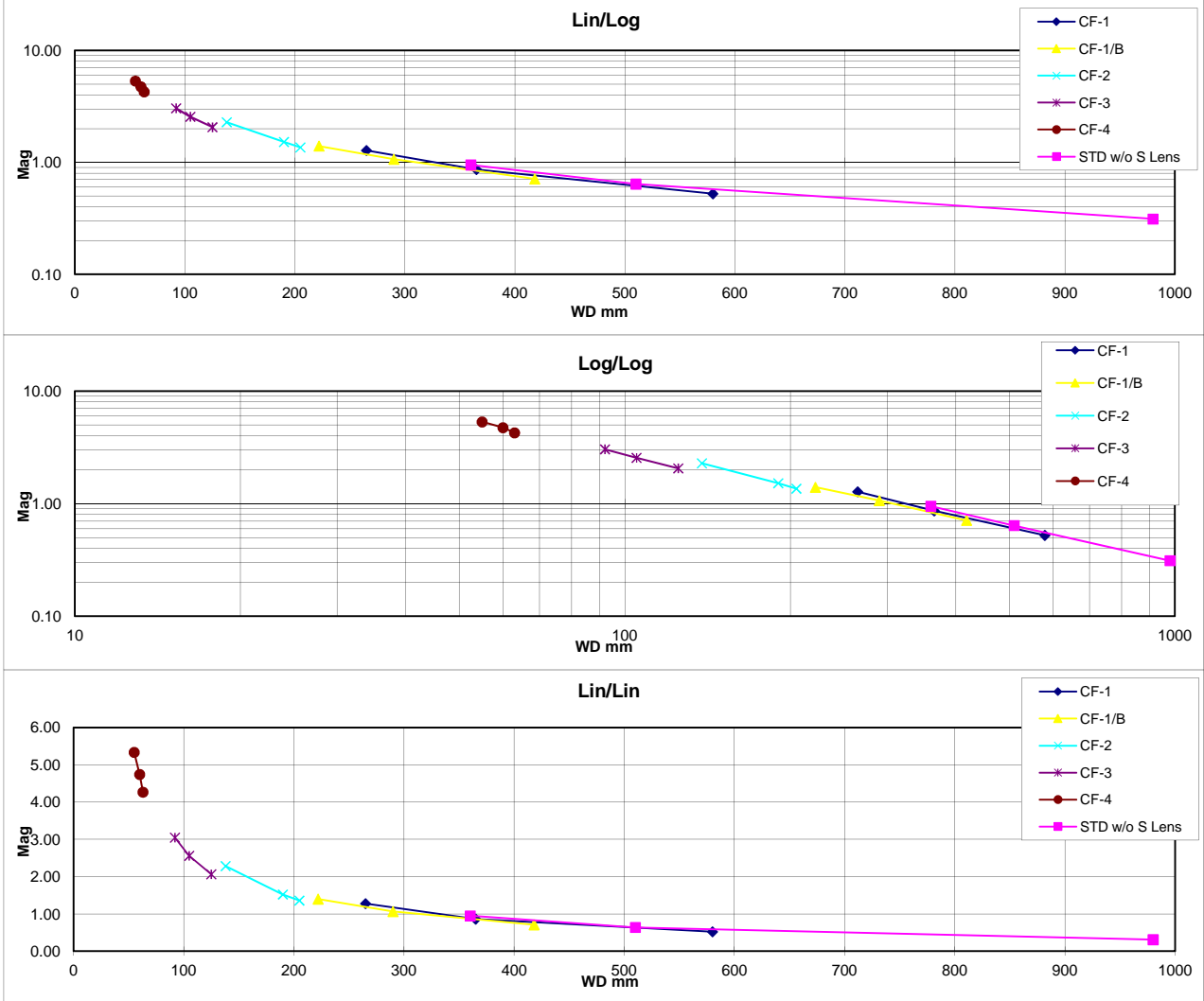

MODEL K2/SC OPTICAL RESOLUTION DATA STANDARD AND CF-OBJECTIVES WITHOUT S LENS

Model K2/SC	STD w/o S Lens			CF-1			CF-1/B			CF-2			CF-3			CF-4		
	Near	Mid	Far	Near	MID	Far	Near	MID	Far	Near	MID	Far	Near	MID	Far	Near	MID	Far
WDmm	360	510	980	265	365	580	222	290	418	138	190	205	125	55	60	63		
MAG	0.95	0.64	0.31	1.28	0.86	0.52	1.40	1.07	0.71	2.29	1.52	1.36	3.05	2.56	2.06	5.33	4.74	4.27
NA	0.053	0.037	0.019	0.072	0.052	0.033	0.086	0.066	0.045	0.138	0.100	0.093	0.207	0.181	0.152	0.200	0.183	0.175
Resolution (lpmm)	158	112	58	215	156	98	257	197	136	413	300	278	620	543	456	600	550	524
Resolution (microns)	6.3	8.9	17.2	4.6	6.4	10.2	3.9	5.1	7.3	2.4	3.3	3.6	1.6	1.8	2.2	1.7	1.8	1.9
DOFmm	0.20	0.39	1.45	0.11	0.20	0.51	0.07	0.13	0.26	0.03	0.05	0.06	0.01	0.02	0.02	0.01	0.02	0.02

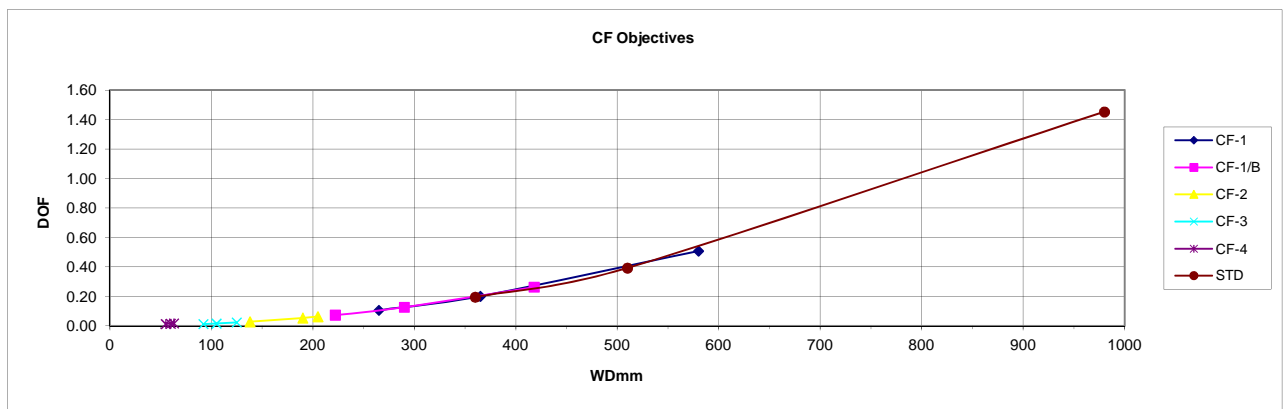
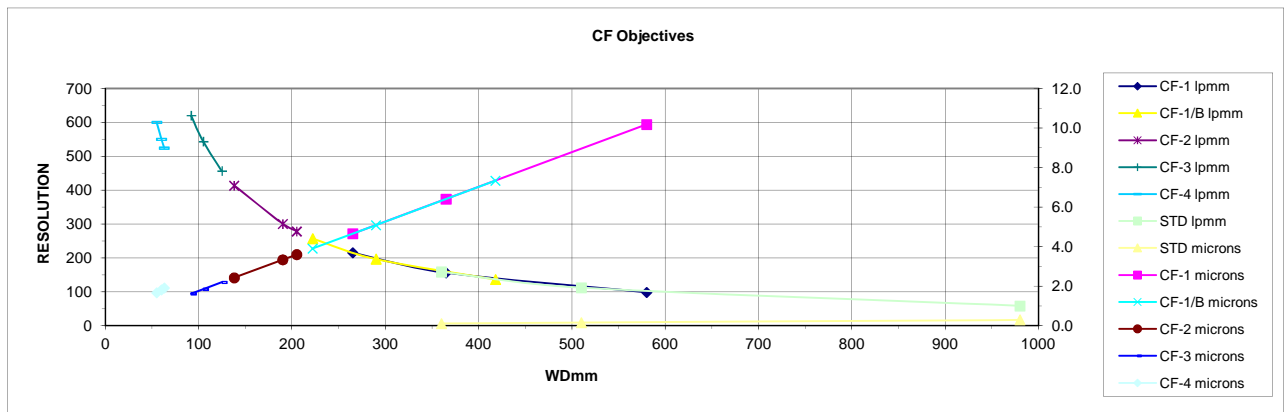
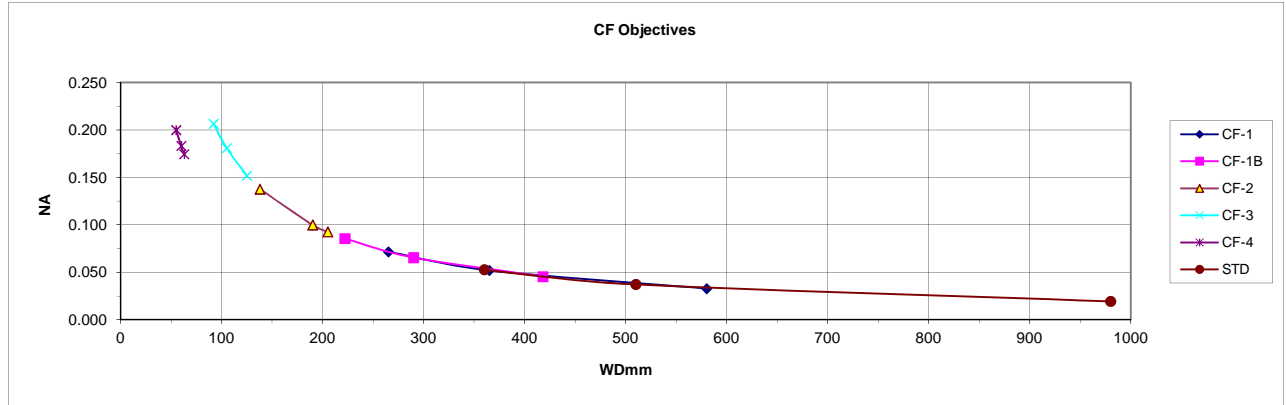

This drawing is for informational purposes only.
No other rights or privileges are granted or implied.

REVISIONS				
ZONE	REV	DESCRIPTION	DATE	APPROVED

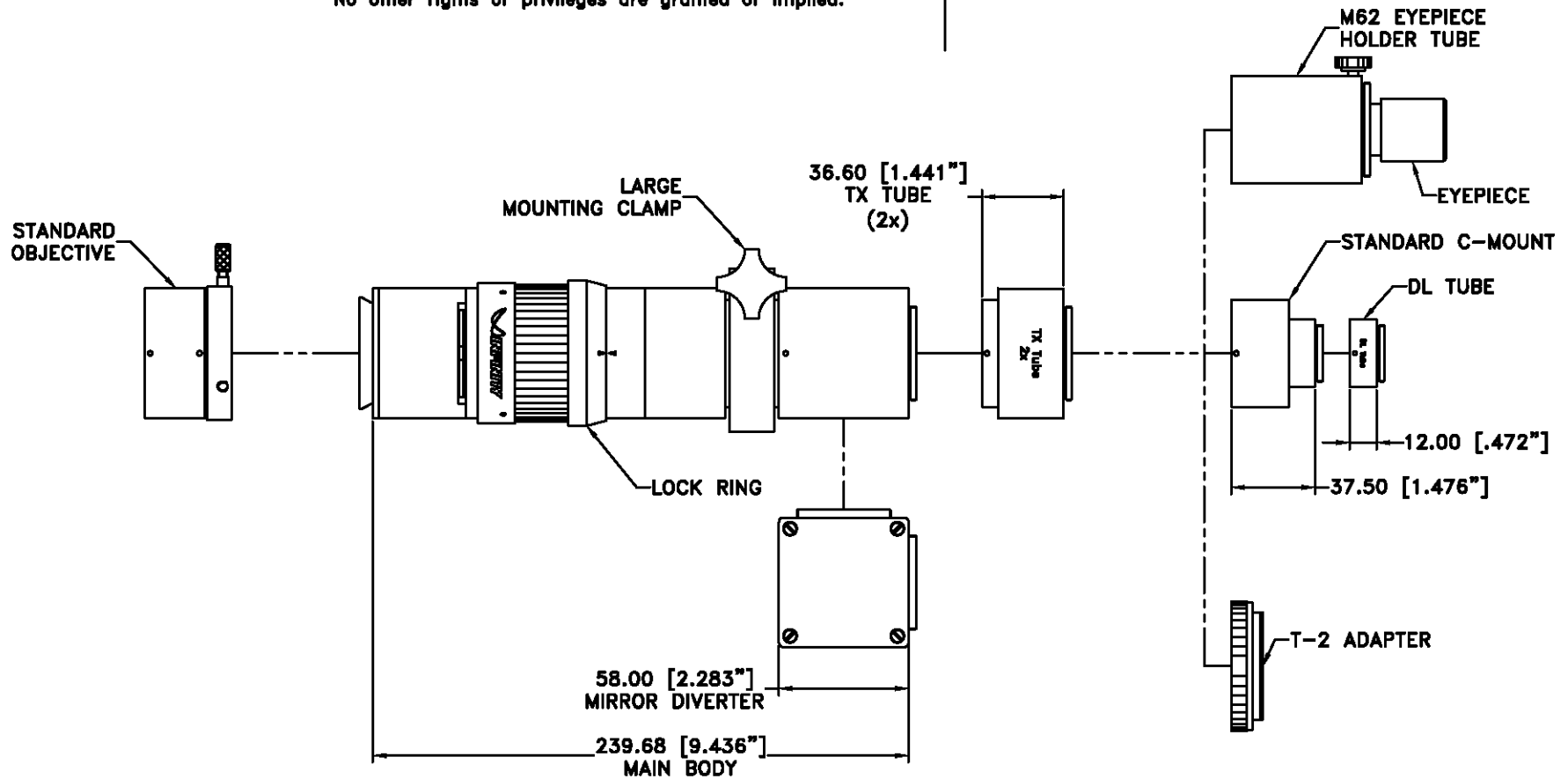

ALL DIM ARE mm [Inches] AND ARE FOR REFERENCE ONLY AND ARE SUBJECT TO CHANGE.

INFINITY Photo-Optical Company
2530 Frontier Ave., Boulder, CO 80301
303/440-4544 Fax 303/440-4144

MODEL K2/SC with S Lens in system

Date: 06/22/09 MB	SIZE B	FSCM NO.	DWG NO.	-	REV -
Modified:	SCALE NONE	-	SHEET 1 OF 1		

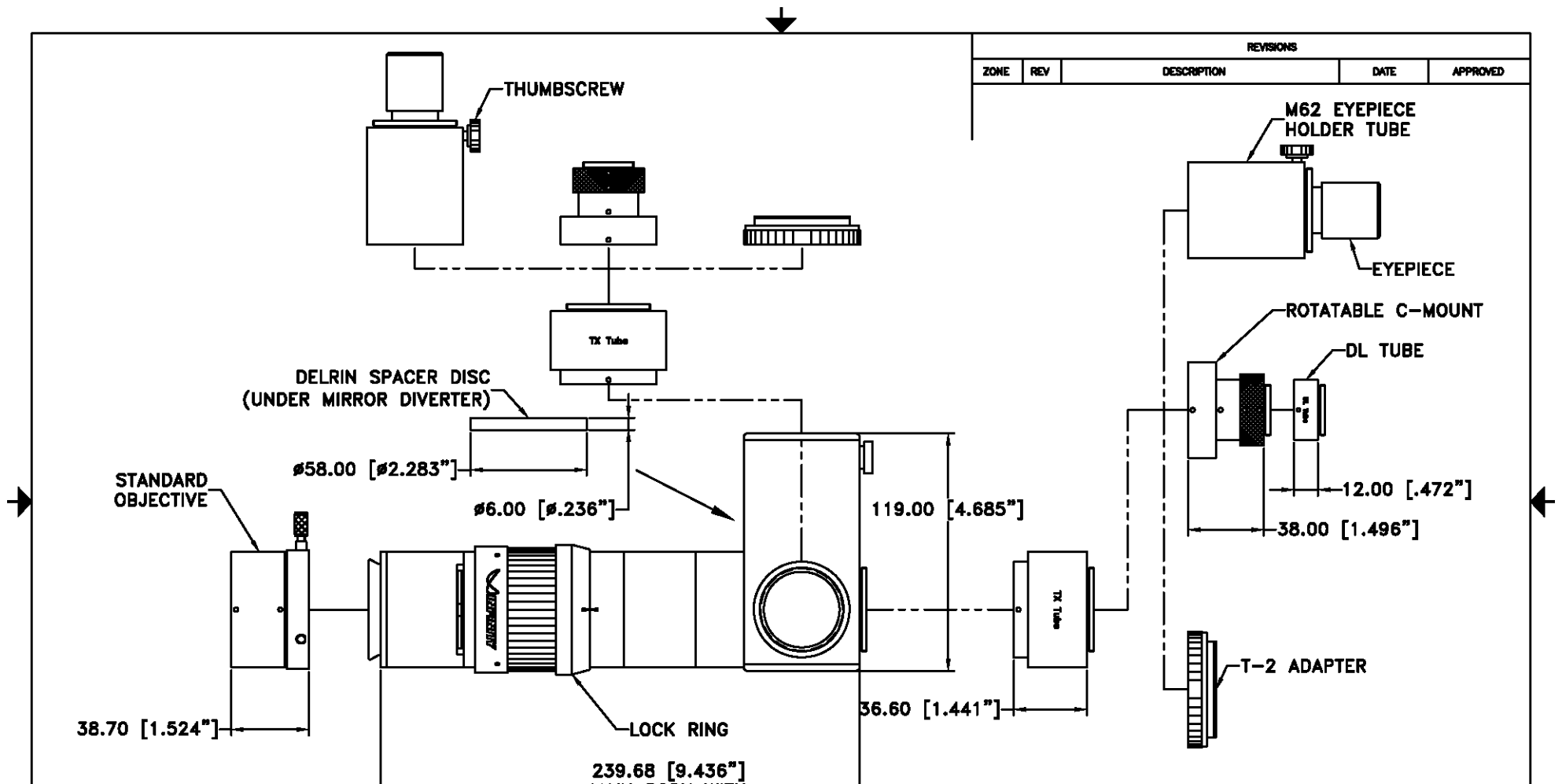

REVISIONS				
ZONE	REV	DESCRIPTION	DATE	APPROVED

This drawing is for informational purposes only.
No other rights or privileges are granted or implied.

ALL DIM ARE mm
[Inches] AND ARE FOR
REFERENCE ONLY AND
ARE SUBJECT TO
CHANGE.

INFINITY Photo-Optical Company
2530 Frontier Ave., Boulder, CO 80301
303/440-4544 Fax 303/440-4144

**MODEL K2/SC w/S LENS AND
MIRROR DIVERTER**

Date: 05/05/09 MB	SIZE B	FSCM NO.	DWG NO. -	REV -
Modified:	SCALE NONE	-	SHEET 1 OF 1	

This drawing is for informational purposes only.
No other rights or privileges are granted or implied.

REVISIONS				
ZONE	REV	DESCRIPTION	DATE	APPROVED

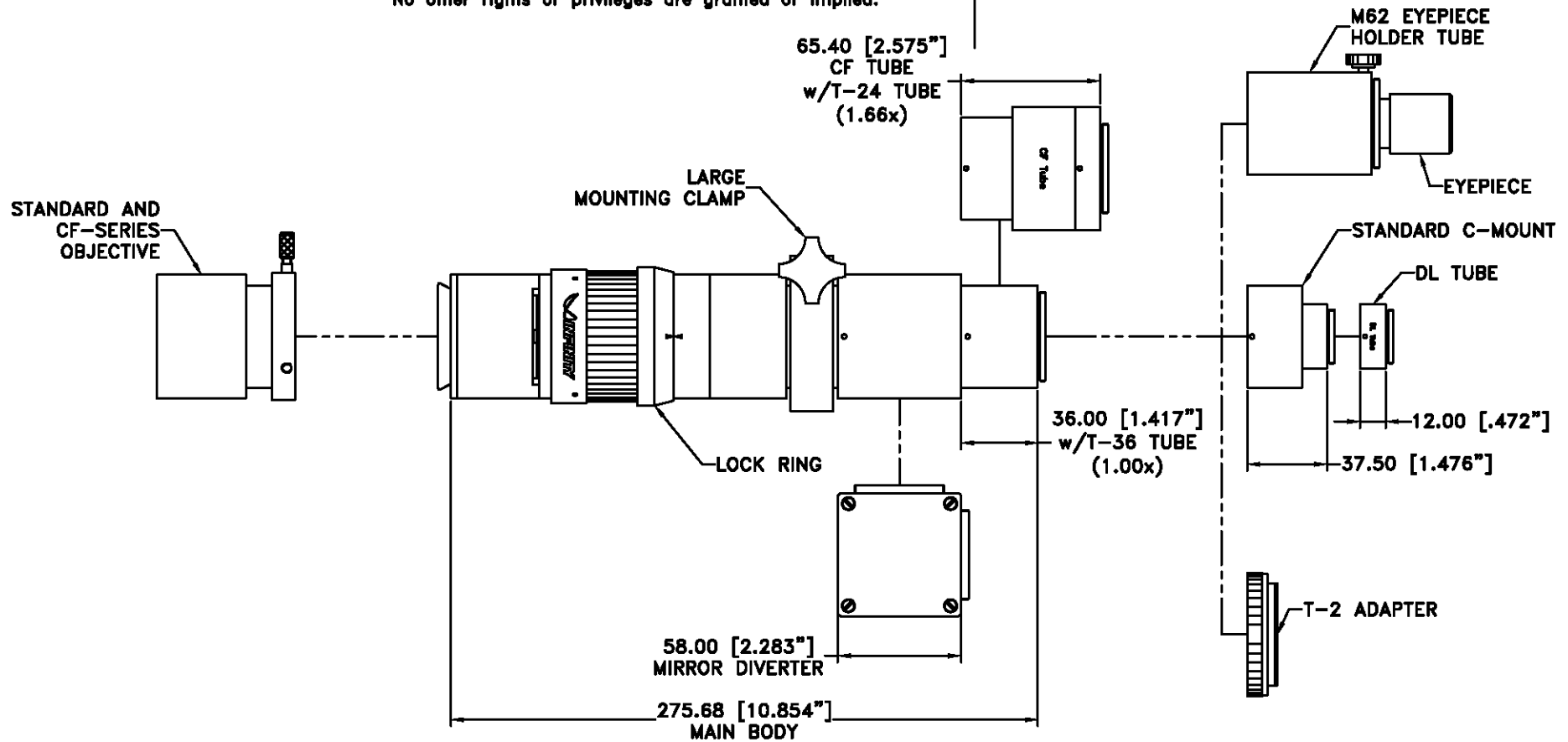

ALL DIM ARE mm [Inches] AND ARE FOR REFERENCE ONLY AND ARE SUBJECT TO CHANGE.

INFINITY Photo-Optical Company
2530 Frontier Ave., Boulder, CO 80301
303/440-4544 Fax 303/440-4144

MODEL K2/SC w/o S LENS

Date: 04/22/09 MB	SIZE B	FSCM NO.	DWG NO.	REV -
Modified:	SCALE NONE	-	SHEET 1 OF 1	

REVISIONS				
ZONE	REV	DESCRIPTION	DATE	APPROVED

LARGE MOUNTING CLAMP

SUPPLIED T-36 TUBE
NOW MOVES TO THIS
POSITION.

M42 x 0.75

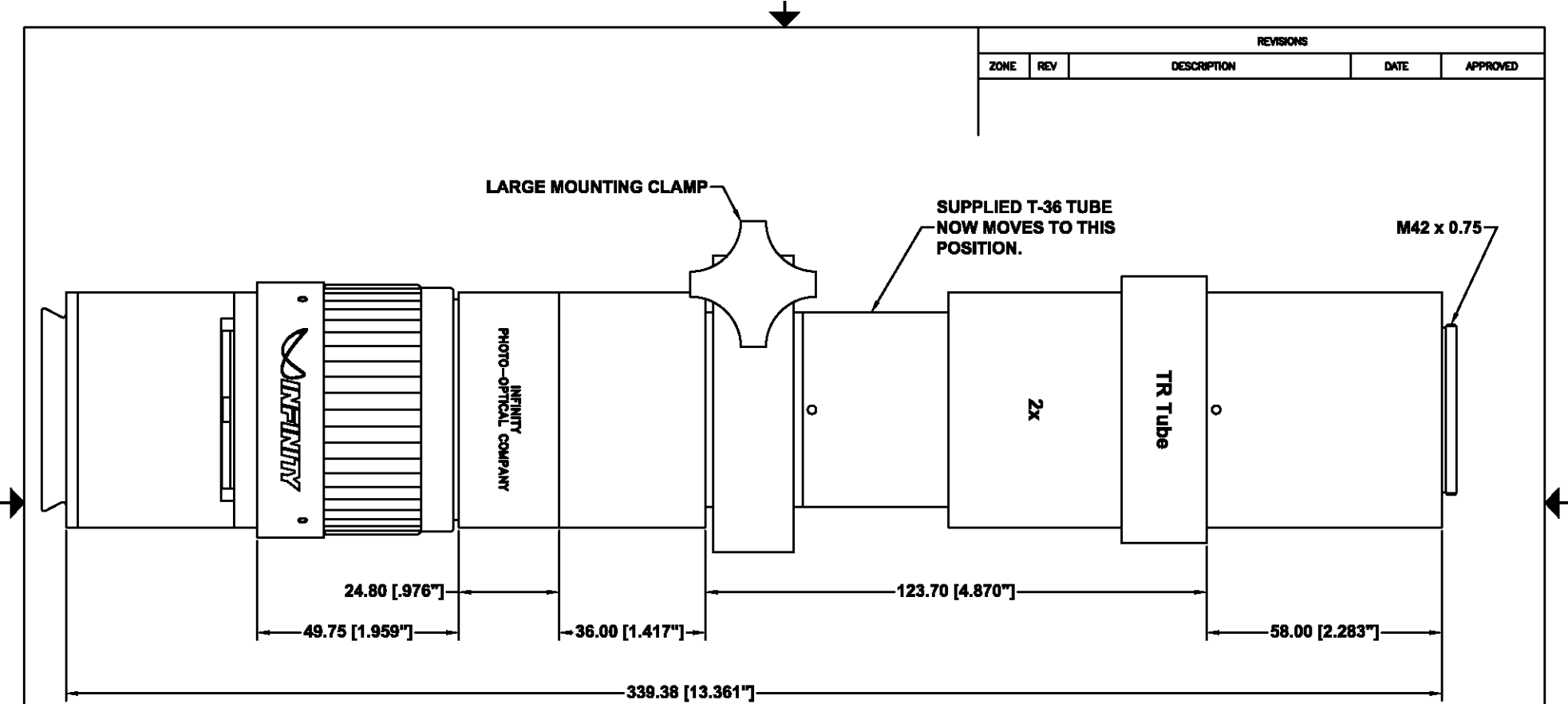

ALL DIM ARE mm
[Inches] AND ARE FOR
REFERENCE ONLY AND
ARE SUBJECT TO
CHANGE.

INFINITY Photo-Optical Company
2530 Frontier Ave., Boulder, CO 80301
303/440-4544 Fax 303/440-4144

**MODEL K2/SC WITH TR TUBE AND
T-36 TUBE**

Date: 11/08/11 MB	SIZE B	FSCM NO.	DWG NO. -	REV -
Modified:	SCALE NONE	-	SHEET 1 OF 1	

This drawing is for informational purposes only.
No other rights or privileges are granted or implied.

REVISIONS				
ZONE	REV	DESCRIPTION	DATE	APPROVED

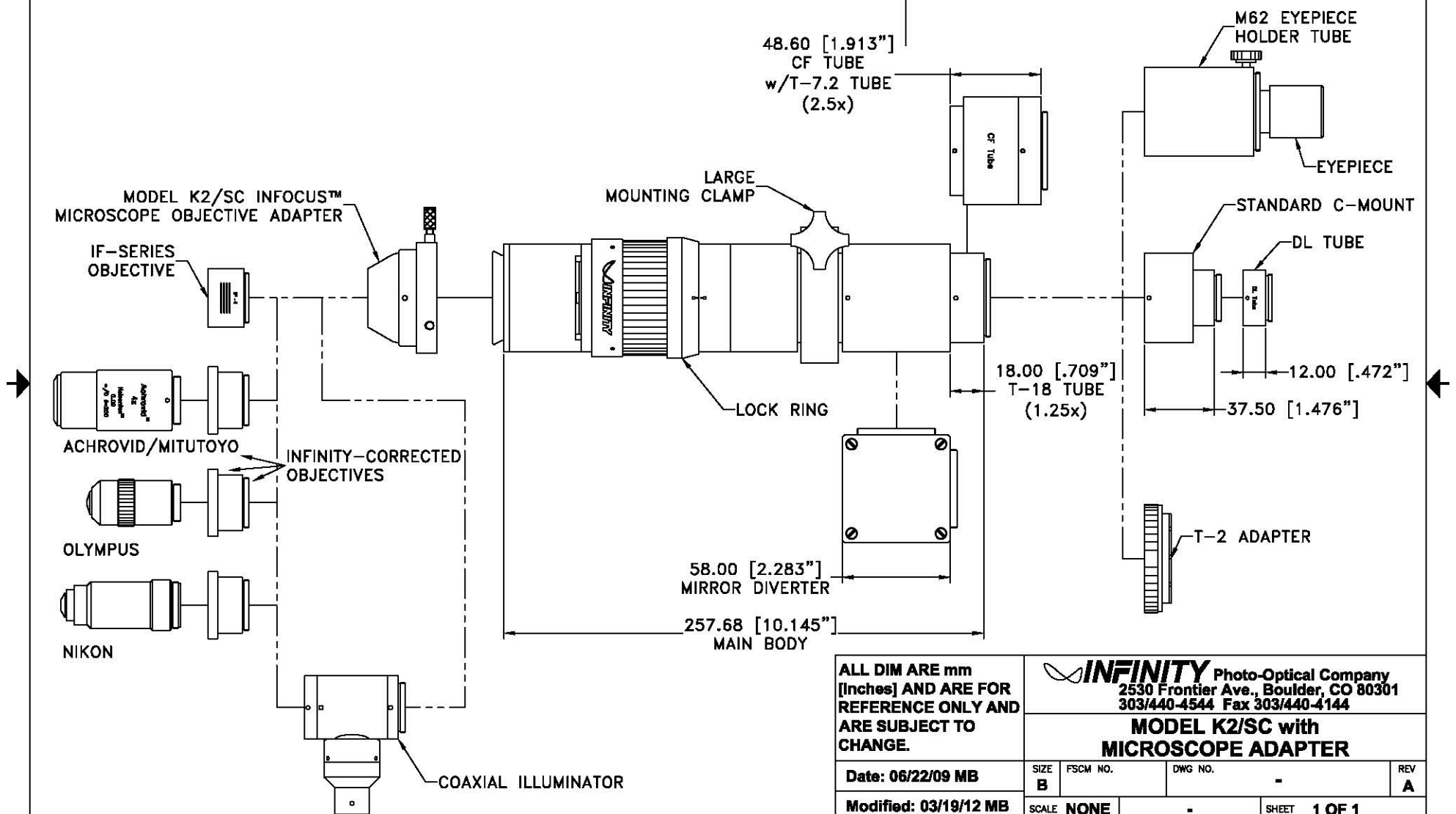

ALL DIM ARE mm [Inches] AND ARE FOR REFERENCE ONLY AND ARE SUBJECT TO CHANGE.

INFINITY Photo-Optical Company
2530 Frontier Ave., Boulder, CO 80301
303/440-4544 Fax 303/440-4144

MODEL K2/SC with MICROSCOPE ADAPTER

Date: 06/22/09 MB	SIZE B	FSCM NO.	DWG NO. -	REV A
Modified: 03/19/12 MB	SCALE NONE		SHEET 1 OF 1	

This drawing is for informational purposes only.
No other rights or privileges are granted or implied.

REVISIONS				
ZONE	REV	DESCRIPTION	DATE	APPROVED

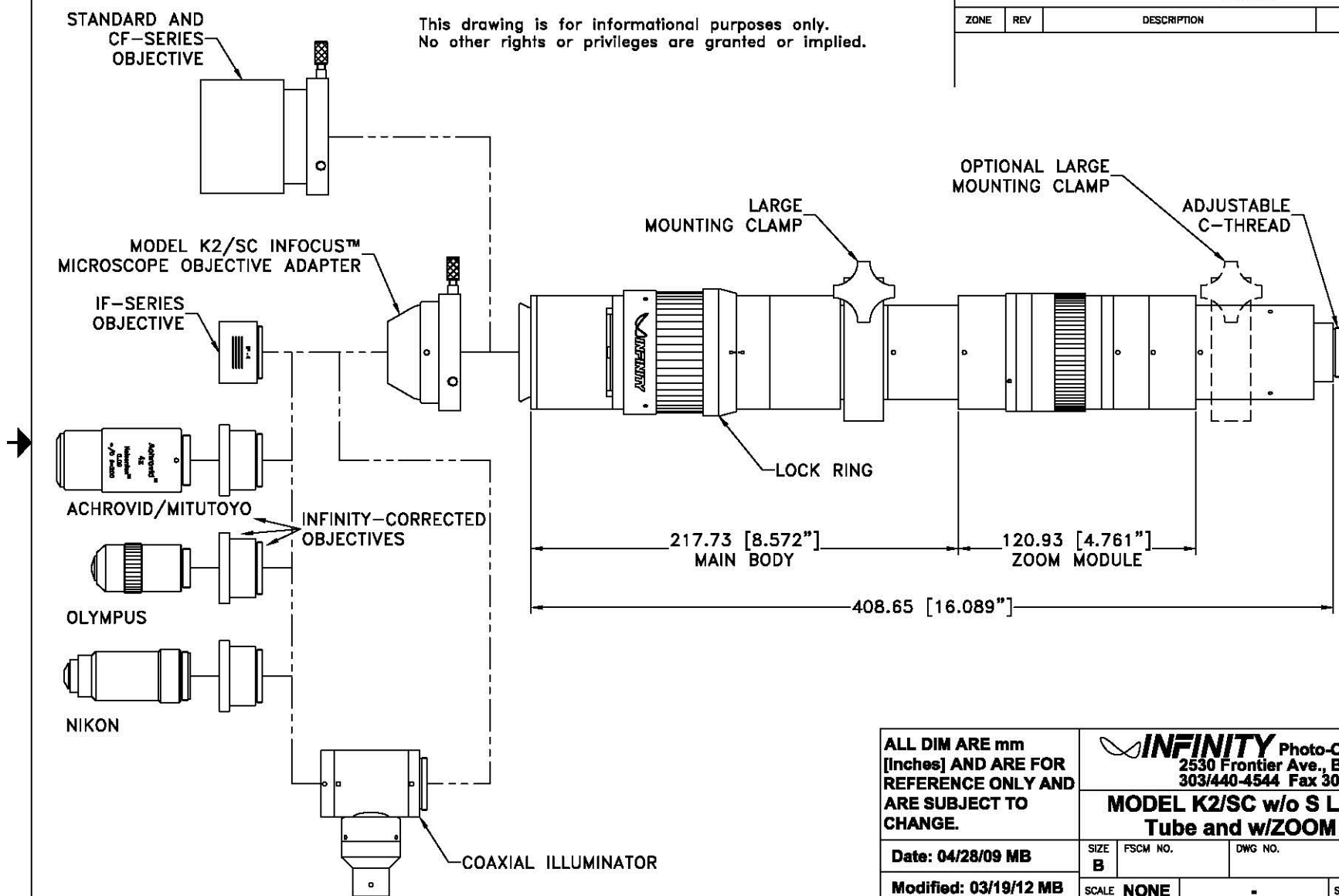

ALL DIM ARE mm
[Inches] AND ARE FOR
REFERENCE ONLY AND
ARE SUBJECT TO
CHANGE.

INFINITY Photo-Optical Company
2530 Frontier Ave., Boulder, CO 80301
303/440-4544 Fax 303/440-4144

**MODEL K2/SC w/o S LENS & 36mm
Tube and w/ZOOM MODULE**

Date: 04/28/09 MB	SIZE B	FSCM NO.	DWG NO. -	REV A
Modified: 03/19/12 MB	SCALE NONE	-	SHEET 1 OF 1	

REVISIONS				
ZONE	REV	DESCRIPTION	DATE	APPROVED

This drawing is for informational purposes only.
No other rights or privileges are granted or implied.

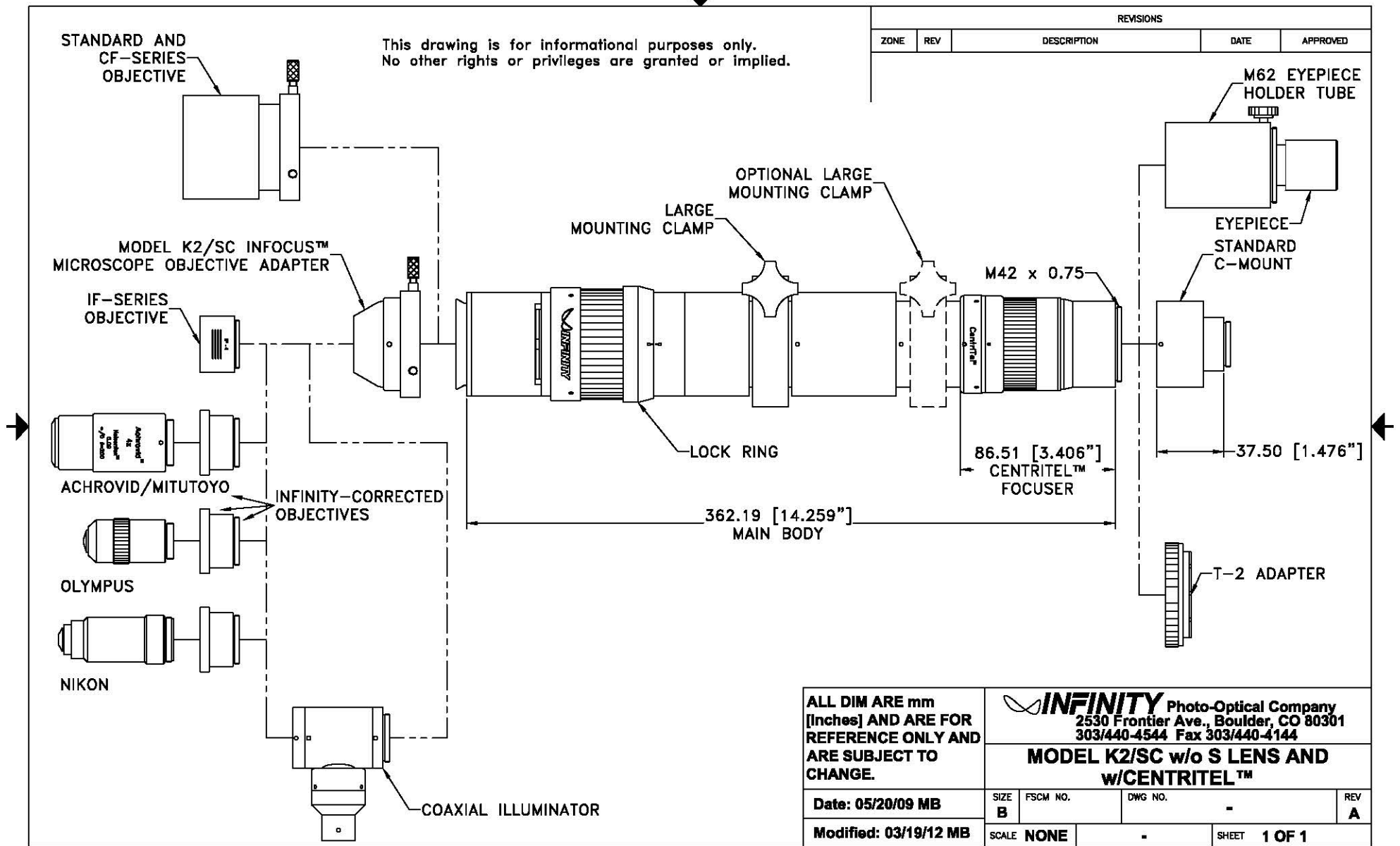

ALL DIM ARE mm
[Inches] AND ARE FOR
REFERENCE ONLY AND
ARE SUBJECT TO
CHANGE.

INFINITY Photo-Optical Company
2530 Frontier Ave., Boulder, CO 80301
303/440-4544 Fax 303/440-4144

**MODEL K2/SC w/o S LENS AND
w/CENTRITEL™**

Date: 05/20/09 MB	SIZE B	FSCM NO.	DWG NO. -	REV A
Modified: 03/19/12 MB	SCALE NONE	-	SHEET 1 OF 1	

This drawing is for informational purposes only.
No other rights or privileges are granted or implied.

REVISIONS				
ZONE	REV	DESCRIPTION	DATE	APPROVED

STANDARD OBJECTIVE*

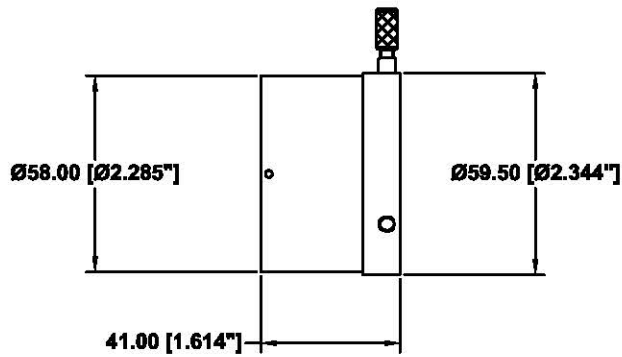

CF-1 OBJECTIVE*

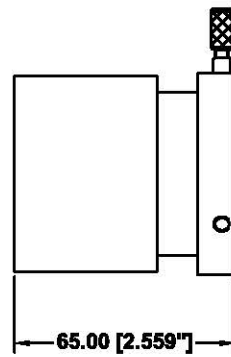

CF-1/B OBJECTIVE*

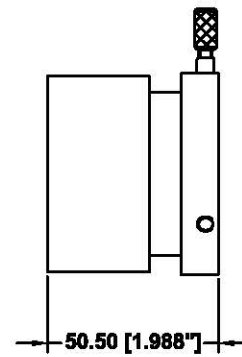

CF-2 OBJECTIVE*

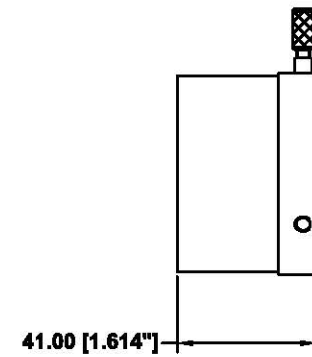

CF-3 OBJECTIVE*

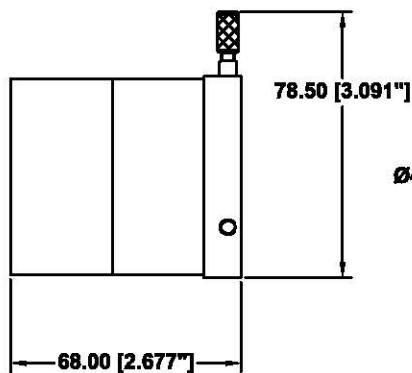

**CF-4 OBJECTIVE
(PRODUCED UNTIL JULY, 2011)**

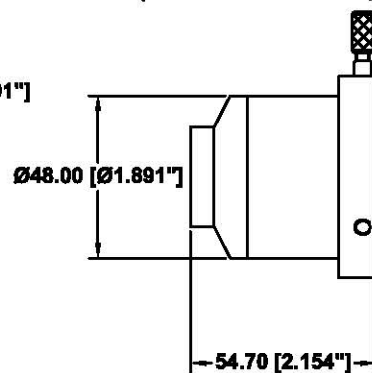

**CF-4 OBJECTIVE
(CURRENT PRODUCTION)**

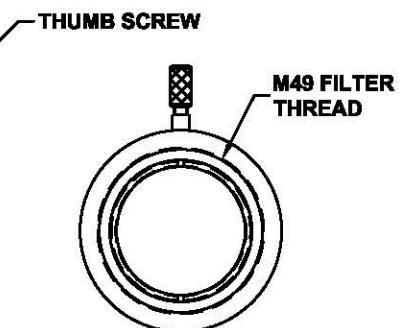
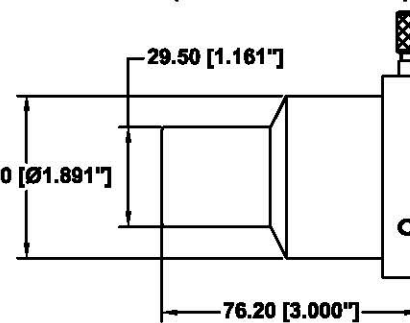

* FRONT ACCEPTS 49mm FILTER

ALL DIM ARE mm
[Inches] AND ARE FOR
REFERENCE ONLY AND
ARE SUBJECT TO
CHANGE.

INFINITY Photo-Optical Company
2530 Frontier Ave., Boulder, CO 80301
303/440-4544 Fax 303/440-4144

MODEL K2/SC OBJECTIVES

Date: 08/05/97 MS

Modified: 06/28/11 MB

SIZE B	FSCM NO.	DWG NO.	REV H
SCALE NONE	-	SHEET 1 OF 1	

This drawing is for informational purposes only.
No other rights or privileges are granted or implied.

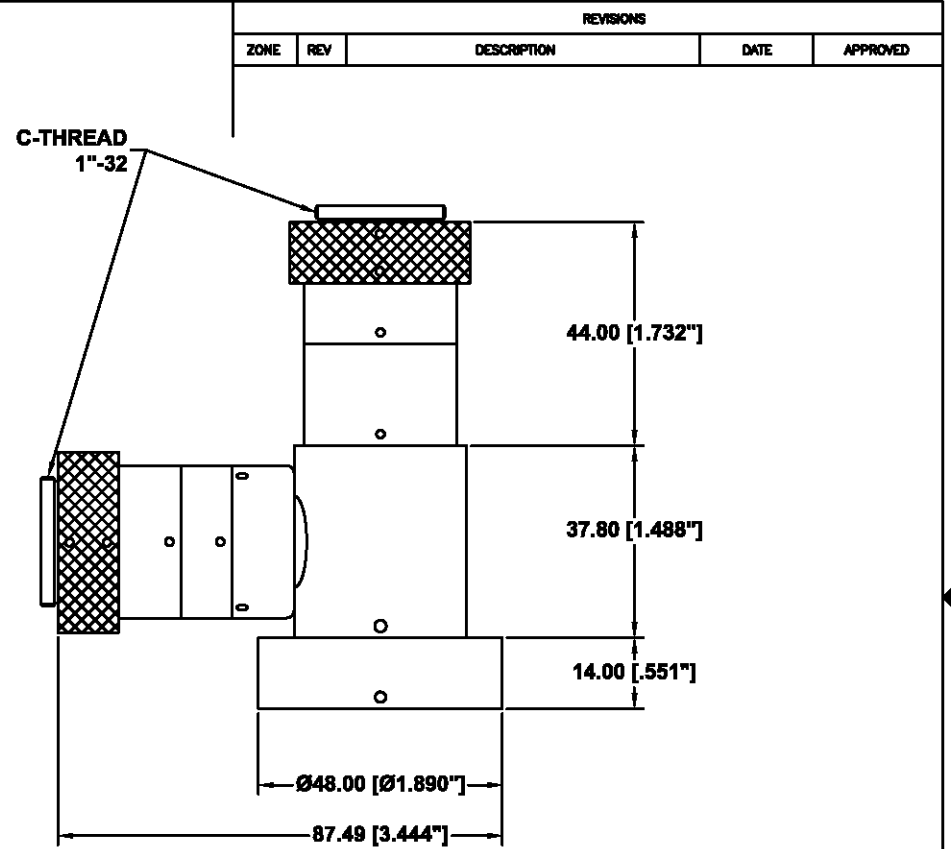
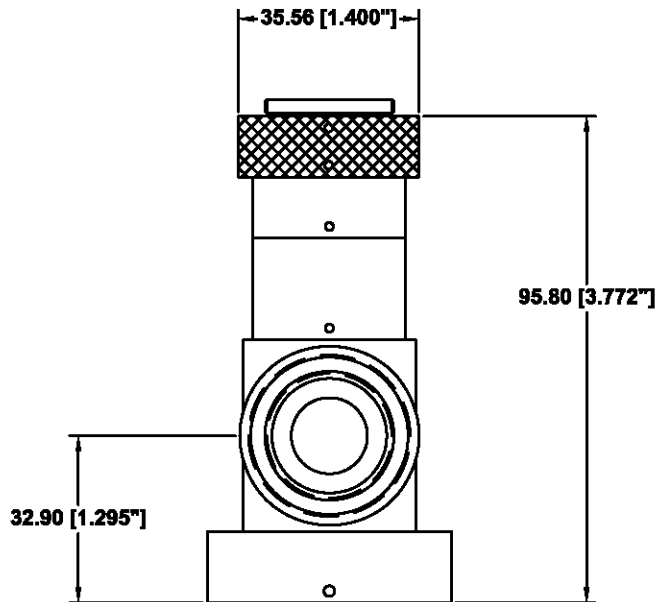

REVISIONS				
ZONE	REV	DESCRIPTION	DATE	APPROVED

THIS UNIT REPLACES A COMBINED 58mm TUBE A C-MOUNT.

<p>ALL DIM ARE mm [Inches] AND ARE FOR REFERENCE ONLY AND ARE SUBJECT TO CHANGE.</p> <p>Date: 06/08/11 MB</p> <p>Modified:</p>	<p>INFINITY Photo-Optical Company 2530 Frontier Ave., Boulder, CO 80301 303/440-4544 Fax 303/440-4144</p> <p>REPLACEMENT C-MOUNT BEAMSPLITTER</p>			
	<p>SIZE B</p> <p>SCALE NONE</p>	<p>FSCM NO.</p> <p>NONE</p>	<p>DWG NO.</p> <p>-</p>	<p>REV</p> <p>-</p>

PHOTO/LARGE-FORMAT VIDEO
SLR BODY (OR LF-VIDEO)
CAMERA

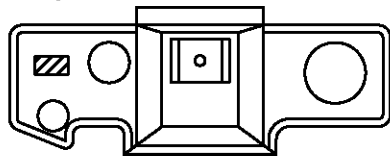

T2 MOUNT



VIDEO CAMERA

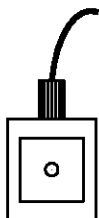

2x DL DOUBLER TUBE

C-MOUNT

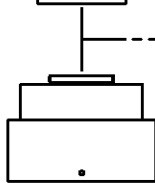

UNIPAR 0.3x
VIDEO/PHOTO ADAPTER

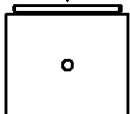

T-30 SPACER

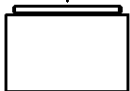

EYEPIECE

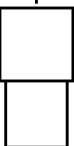

M62 EYEPIECE HOLDER

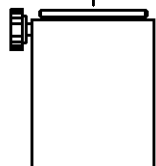

ATTACH TO INSTRUMENT

REVISIONS				
ZONE	REV	DESCRIPTION	DATE	APPROVED

ALL DIM ARE mm [inches]
AND ARE FOR
REFERENCE ONLY AND
ARE SUBJECT TO
CHANGE.

INFINITY Photo-Optical Company
2530 Frontier Ave., Boulder, CO 80301
303/440-4544 Fax 303/440-4144

**PHOTO/VIDEO MICROGRAPHIC
OPTIONS**

Date: 08/28/97 MS	SIZE B	FSCM NO.	DWG NO.	REV C
Modified: 05/01/09 MB	SCALE NONE	-	SHEET 1 OF 1	

REVISIONS				
ZONE	REV	DESCRIPTION	DATE	APPROVED

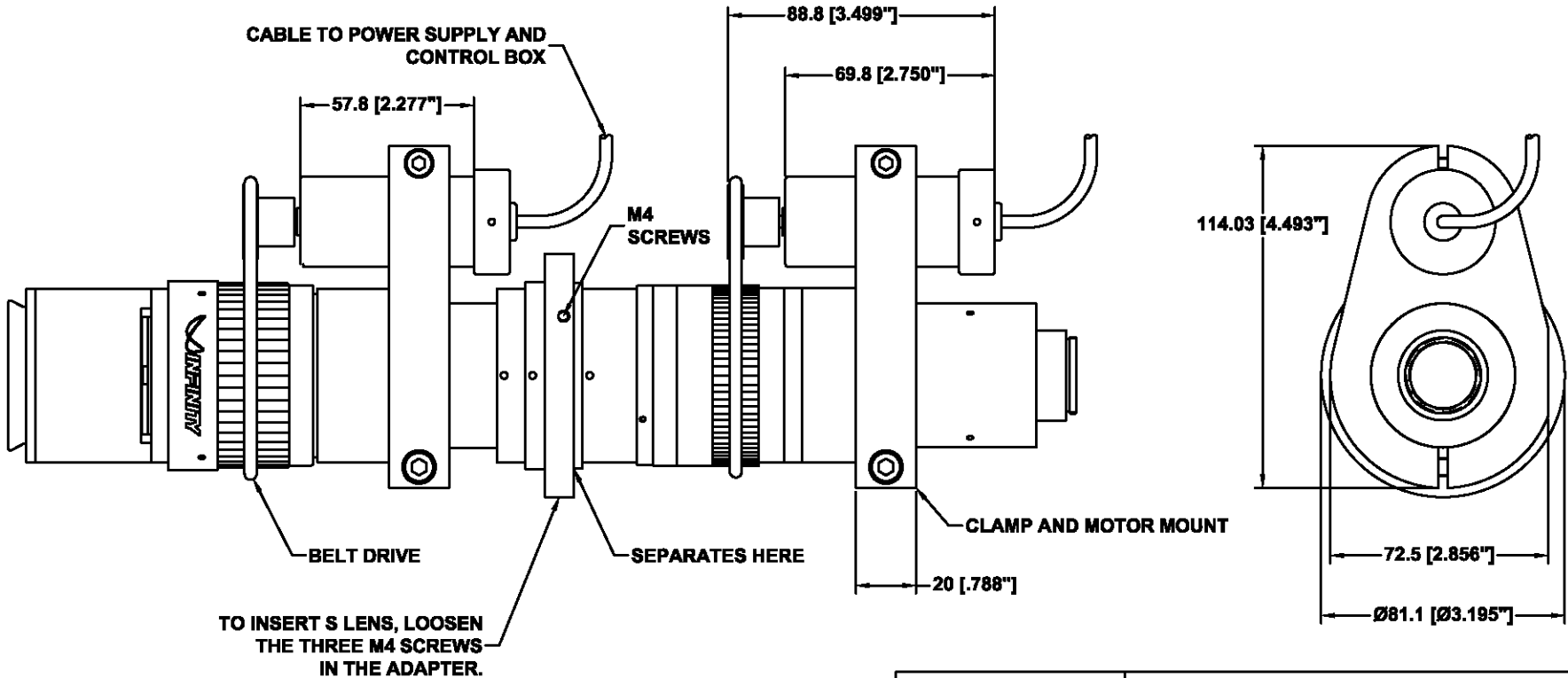

TO INSERT S LENS, LOOSEN THE THREE M4 SCREWS IN THE ADAPTER.

ALL DIM ARE mm [Inches] AND ARE FOR REFERENCE ONLY AND ARE SUBJECT TO CHANGE.

INFINITY Photo-Optical Company
 2530 Frontier Ave., Boulder, CO 80301
 303/440-4544 Fax 303/440-4144

MODEL K2/SC WITH ZOOM AND TWO MOTOR DRIVES w/S LENS

Date: 10/09/97 MS

SIZE B	FSCM NO.	DWG NO. -	REV B
-----------	----------	--------------	----------

Modified: 06/24/09 MB

SCALE NONE	-	SHEET 1 OF 1
---------------	---	-----------------

SIDE

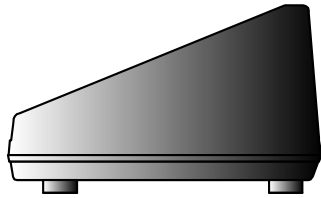

FRONT



REAR

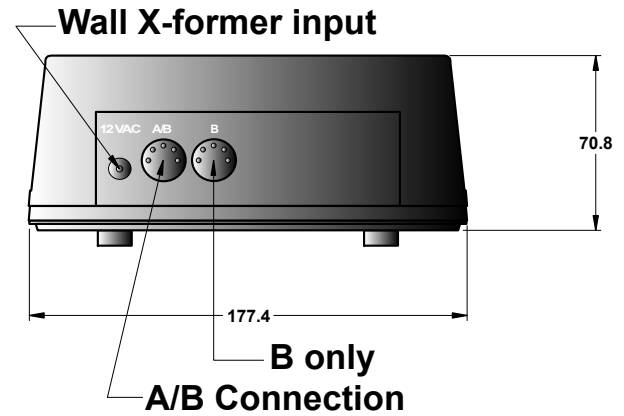

Power LED

Select A or B Motor

126.9

TOP

Forward/Reverse Paddle Momentary Center Off Switch

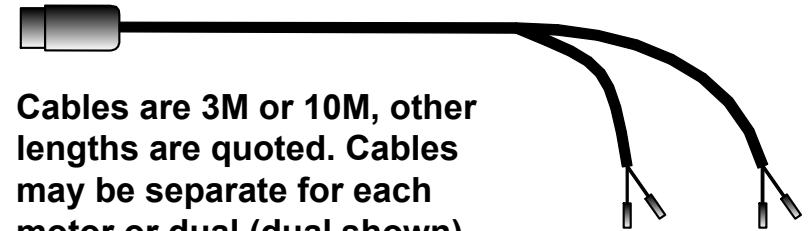

Cables are 3M or 10M, other lengths are quoted. Cables may be separate for each motor or dual (dual shown).

This drawing is for informational purposes only. No other rights or privileges are granted or implied.

ALL DIM ARE mm [inches] AND ARE FOR REFERENCE ONLY AND ARE SUBJECT TO CHANGE.

INFINITY Photo-Optical Company
2530 Frontier Ave., Boulder, CO 80301
303/440-4544 Fax 303/440-4144

MSE1650 Motor Controller

Date: 10/14/97	SIZE B	FSCM NO.	DWG NO.	REV
Modified:	SCALE NONE	SHEET 1 OF 1		

**This drawing is for informational purposes only.
No other rights or privileges are granted or implied.**

REVISIONS				
ZONE	REV	DESCRIPTION	DATE	APPROVED

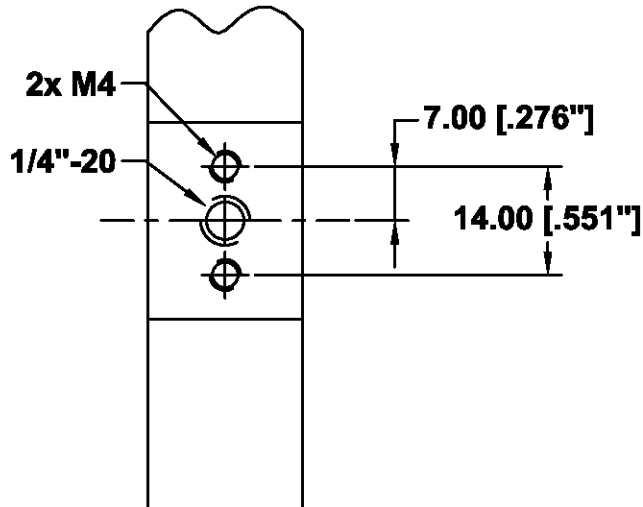
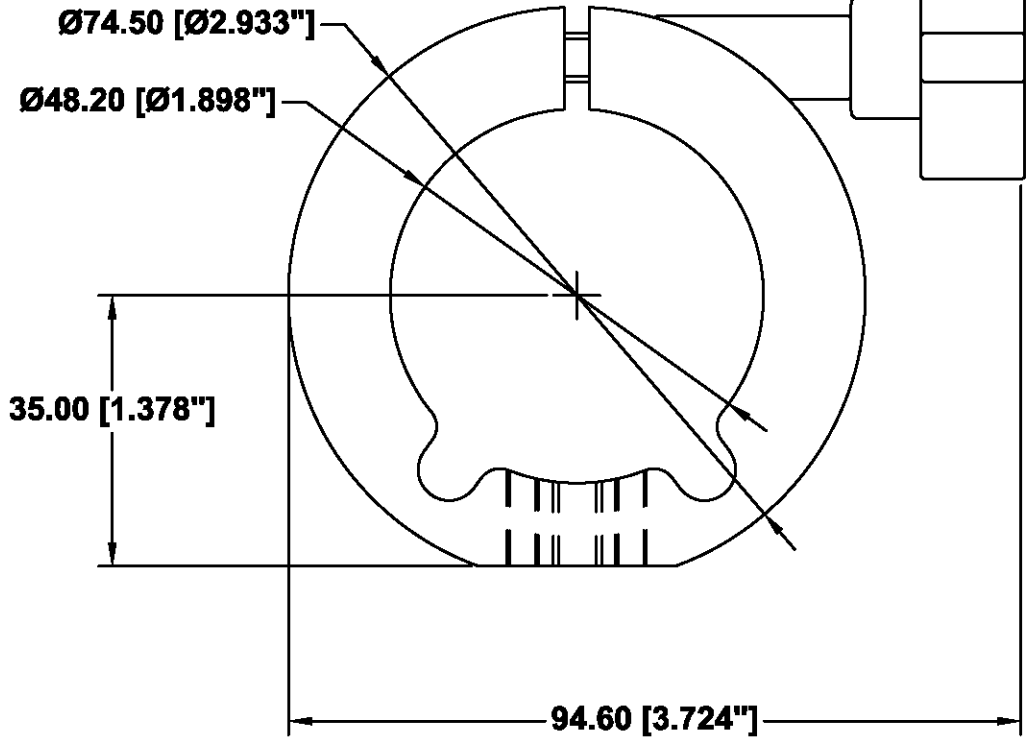
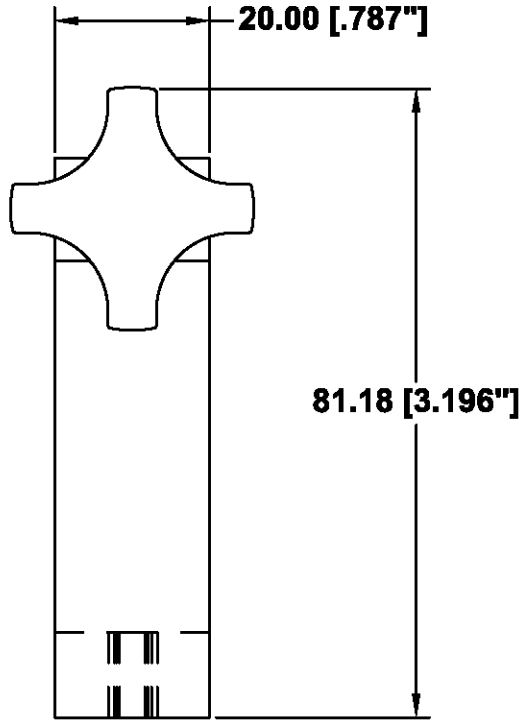

ALL DIM ARE mm [inches] AND ARE FOR REFERENCE ONLY AND ARE SUBJECT TO CHANGE.

INFINITY Photo-Optical Company
2530 Frontier Ave., Boulder, CO 80301
303/440-4544 Fax 303/440-4144

LARGE MOUNTING CLAMP

Date: 07/24/97 MS		SIZE A	FSCM NO.	DWG NO. 770 170	REV -
Modified: 08/10/05 MB		SCALE NONE	-	SHEET 1 OF 1	

INFINITY PHOTO-OPTICAL COMPANY LIMITED WARRANTY

INFINITY PHOTO-OPTICAL COMPANY hereby warrants its products to be free from defects in workmanship or materials for the warranty period set forth below. INFINITY PHOTO-OPTICAL COMPANY, at its option, shall repair or replace the defective product without cost to the purchaser, and such repair or replacement shall be the full extent of this express limited warranty. INFINITY PHOTO-OPTICAL COMPANY shall not be liable for any other damages either direct or consequential.

This warranty is made to the original purchaser, and is effective only on new equipment purchased from INFINITY PHOTO-OPTICAL COMPANY, or a dealer authorized by INFINITY PHOTO-OPTICAL COMPANY to sell the product.

This warranty is valid only when the product is returned to the authorized dealer from whom it was purchased, or returned directly to INFINITY PHOTO-OPTICAL COMPANY, freight prepaid, with proof of date of purchase.

This warranty does not extend to any defect, malfunction or failure caused by misuse, abuse or the use of the product with equipment for which it may not have been intended. Any unauthorized repair voids this warranty.

The warranty period for all products manufactured by INFINITY PHOTO-OPTICAL COMPANY is five (5) years from date of original purchase. Parts or components made or sourced from other manufacturers shall be solely covered by that manufacturer's warranty.

The warranty contained herein is the only warranty made by INFINITY PHOTO-OPTICAL COMPANY. Any implied warranty of merchantability and/or fitness for a particular purpose is expressly excluded from this warranty. INFINITY PHOTO-OPTICAL COMPANY shall not be liable for any expense, loss, incidental or consequential damages which may arise in connection with the use of this equipment. Recovery under this warranty is limited to repair or replacement of the equipment as provided above.

INFINITY PHOTO-OPTICAL COMPANY reserves the right to modify designs, equipment and accessories without notice.