

INFINIPROBE™ TS-160 UNIVERSAL INSTRUCTIONS FOR USE

You are about to experience a radically new approach to macro/micro imaging. It has a Variable Iris, but no f/stops and it focuses internally without any changes to its outer dimensions. It ranges magnification from 0 to as much as 16x. Almost any camera up to and including those with 35mm sensors can be used with it. It is so easy to use that it literally sets the best image for you every time you focus. It may be a "counter-intuitive" experience even to *experienced* photographers. It is the InfiniProbe TS-160 from Infinity Photo-Optical Company. Quality macro/micro imaging has become *simple and easy*.

Recently, new accessories and the availability of a PL Arri-type mount have extended the TS-160's uses into advanced cinematographic capabilities. Now, a single lens can be used for imaging from MICRO and MACRO to table-top advertising, motion pictures, and wherever incredible depth of field is envisioned. Truly, the TS-160 has now advanced to the front rank of special optics. Please see "Cinematography with the TS-160" section for further details.

QUICK-START CHECKLIST:

- 1) Mount the TS-160/camera on any suitable support—from a tripod to a boom stand—and use a suitable form of illumination.
- 2) Move the TS-160 up or down, closer or farther from an object to select a magnification.
- 3) Turn the Focusing Ring to focus on the object.
- 4) Close-down the Variable Iris until you see the *first* "jump" in contrast.
- 5) *Without moving the TS-160*, turn the Focusing Ring to focus *slightly* above and below your originally-chosen plane.
- 6) If you see blurring equal on both sides of focus, STOP and re-focus to the originally-chosen plane. If blurring is not *quite* equal on both sides of focus, *slightly* close-down a bit more until it is.

Once you see blurring equal on both sides of focus, you will have set the *best possible image* from the TS-160.

The TS-160 System. The TS-160 consists of a Main Body which contains a patent-pending internally-focusable optical system, activated by a Focusing Ring which turns 360-degrees. Inside is a provision for 25mm diameter filters (for example, polarizers or fluorescence types). At its rear is one at least a T24mm tube which allows access to accessories when it is temporarily removed or exchanged with a mount for use on a stereo microscope stand. A Clamp and optional Mounting Bar are available so that the TS-160 can be mounted on tripods or fixtures via 1/4-20 or two "outboard" M4 taps. A Variable Iris allows contrast and aberrational control.

The InfiniProbe TS-160 is not a zoom lens. Its optical configuration may be best described as being a continuously-focusable microscope. This means you can focus on any suitable object at a distance and move in to see it become a single frame at great magnification. Instead of being limited to a single working distance, you can choose whatever standoff you wish. You will never lose sight of your object as you focus closer and closer. As you focus, detail (resolution) increases and depth of field gets shallower. If you need more depth of field, just back up to get what you need. The depth of field and magnification are then balanced for best results.

Objectives. Two objectives can be used on the TS-160 Main Body: Micro HM and Macro. The primary objective is the Micro HM. It is the preferred choice for best results. However, a Macro Objective is included with each TS-160 as a compact option.

Recently, two new objectives have been developed for cinematography: the SFX-1 and the SFX-2. These are spherically and aberrationally corrected for long range applications. Please see the Cinematography section below.

Formats. What makes the TS-160 universal is its format compatibility. Depending on the adapter, the TS-160 can be used with all cameras up to and including 24 x 36mm (35mm format).

Operation. Using the TS-160 is as natural as "stepping closer to get a better look." It is *essential* to understand that the Variable Iris must be used to monitor image quality.

Because the TS-160 is essentially a microscope and not a "taking" or typical "macro" lens, its Variable Iris is analogous to that of a regular laboratory microscope's in the condenser. *Like laboratory microscopes, there are no f/stops to be found—they are not relevant to using the TS-160.* The purpose of the Variable Iris is not to control exposure, but to control contrast, resolution and residual aberrations.

Setting the Variable Iris. The TS-160's internal focusing system allows it to be set for optimal imagery by means of the Variable Iris. Within a reasonable tolerance, microscope-configured optics have only *one theoretically proper point where contrast and resolution are optimized relative to aperture and working distance.* Fortunately, this point is easily seen when a sudden "jump" in contrast happens as the Iris is closed down.

InfiniProbe TS-160 Standard

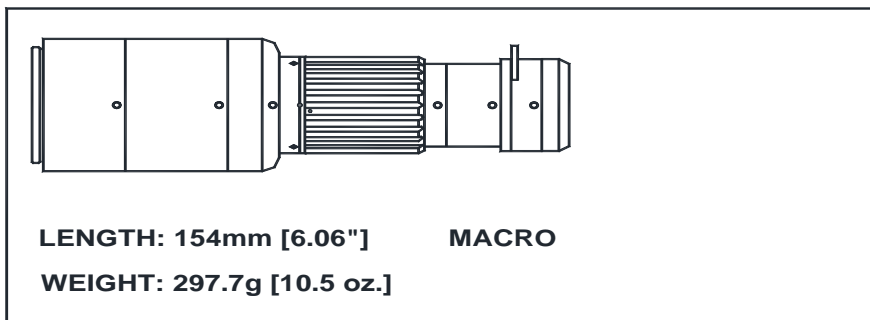
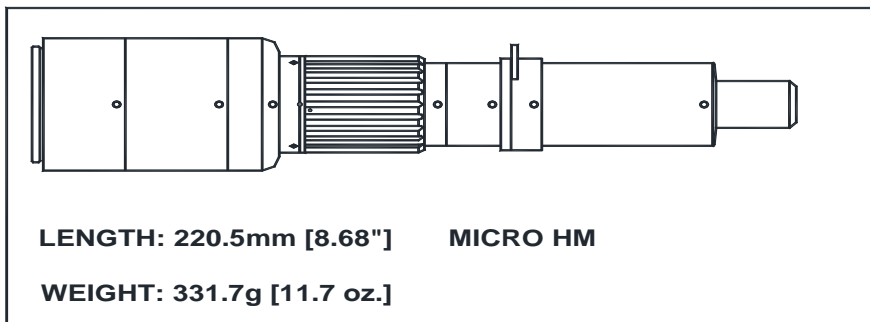

InfiniProbe TS-160 ROBUSTO

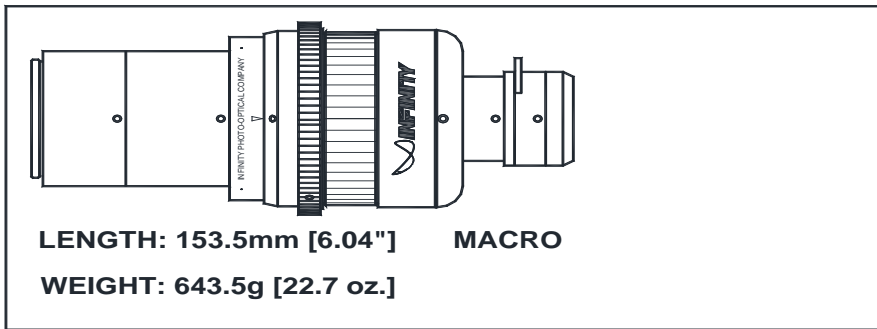
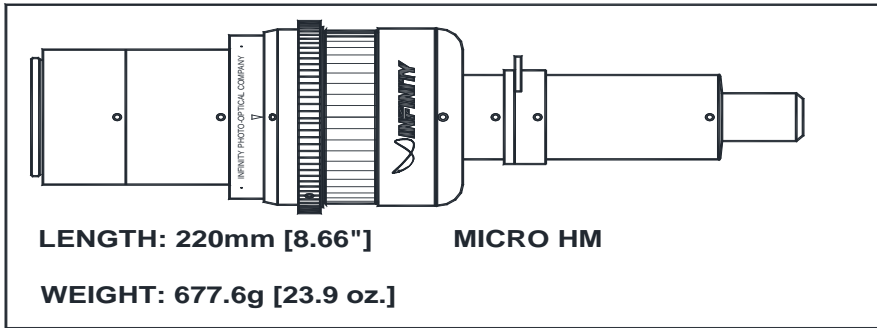

InfiniProbe TS-160 ROBUSTO-Lite

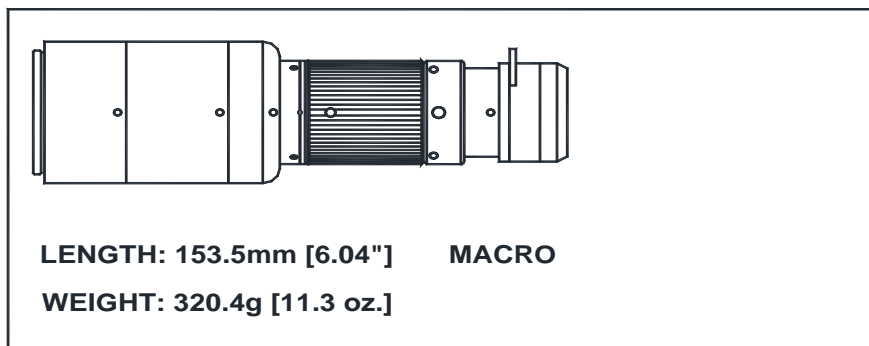
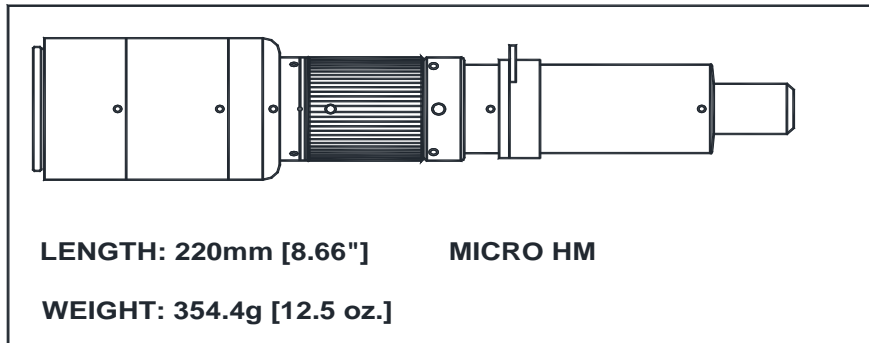

Use with Macro Objective

To use the TS-160 properly with the Macro Objective, simply focus and then stop down the Iris until the contrast "jump" is seen. Then, the advantage of the TS-160's internal focusing allows a slight change to be made in focus above and below the originally-chosen plane *without physically moving it*. If the focus above and below the originally-chosen plane blurs equally at the Iris setting, *that is the optimal point*. Opening or closing the Iris from the optimal point will degrade the image. Still, it should be noted that it is possible—due to the coincidental characteristics of the object—that if equal blurring above and below focus does occur, *that* may indeed be the proper position even if the iris is not activated. In any case, it is always advisable to use several Iris positions for bracketing purposes.

Use with the Micro HM Objective

There is only one Iris position (with slight tolerances) to which the Micro HM and SFX Lenses (see below) must be set. Using it more closed or more open will not provide optimum results. This iris position sets the Focuser for highest performance. Optically, the Iris is not used for any other real purpose with the Micro HM Objective. The sharpest images will result from adherence to this setting.

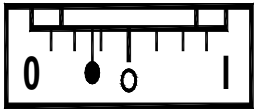

Note: This is the most ideal Iris setting for the HM Objective.

Depth of Field Adjustment. If there is only one point where the best image can be obtained, is closing the Iris to gain depth of field a proper thing to do? This is where the TS-160 is unique. While it is *possible* to close the Iris to increase depth of field, due to optical laws, the image will inevitably be more or less degraded. The TS-160 can provide greater depth of field by moving it *up* or *away* from the object, refocusing and using the Iris to find the best image. In this way, every chosen depth can be taken at the optimal point. You can enlarge the images later, but they will be *captured* with the greatest fidelity.

Cinematography with the TS-160

Cinematographers were quick to see that the ability of the TS-160 to focus out to infinity was of great potential, for example, for shooting commercials and the like. When "focused out" the depth of field is almost perfectly maintained to infinity.

While the TS-160 can be used from 16mm out to infinity when equipped with the Micro HM Objective, that front objective is designed for optimal imagery from 40cm and closer. To solve this, we adapted the TS-160 to use a series of front lens options comprising two SFX Lenses.

Significantly, the opposite correction of the Micro HM Objective applies when the new SFX Lenses are used on the front of the TS-160's Main Body. This Cine Series focus out from 40cm (usefully) to infinity. They are configured on the TS-160 exactly as the Micro HM but have the advantages of better image quality at distance. SFX-1 is the standard of the series. SFX-2 has almost exactly half the magnification but twice the field of view of SFX-1.

Using the Cine Series Lenses is as simple as mounting them on the Main Body and focusing. In general, there is hardly any further need to focus. Then, optimal imagery and depth of field result by simply stopping the iris control to the first observed "jump" in contrast. Nearly all is in focus out to infinity.

The Cine Series Lenses accept scientific grade 25mm filters, M27 photo filters and, with an accessory adapter, M49mm photo filters.

InfiniProbe TS-160 Standard

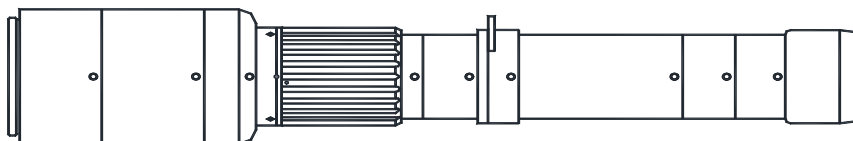

LENGTH: 245mm [9.645"] **SFX-1**

WEIGHT: 385.6g [13.6oz.]

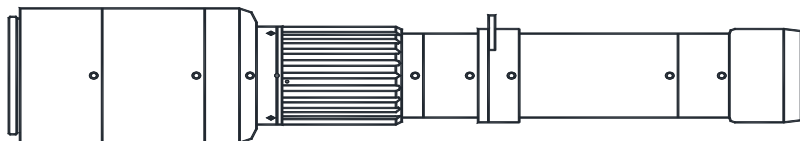

LENGTH: 228.5mm [8.996"] **SFX-2**

WEIGHT: 374.2g [13.2oz.]

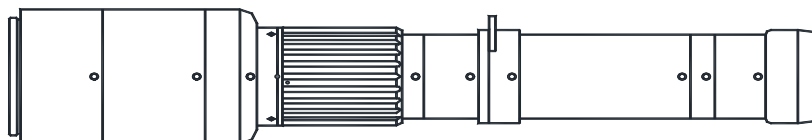

LENGTH: 232.5mm [9.154"] **SFX-3**

WEIGHT: 374.2g [13.2oz.]

InfiniProbe TS-160 ROBUSTO

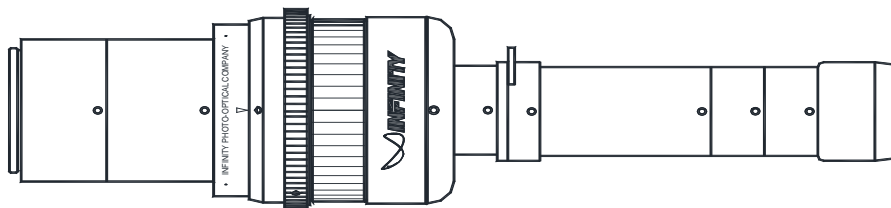

LENGTH: 244.5mm [9.63"] **SFX-1**

WEIGHT: 731.4g [25.8oz.]

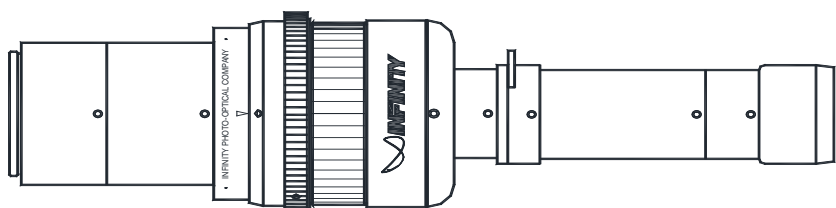

LENGTH: 228mm [8.98"] **SFX-2**

WEIGHT: 720.1g [25.4oz.]

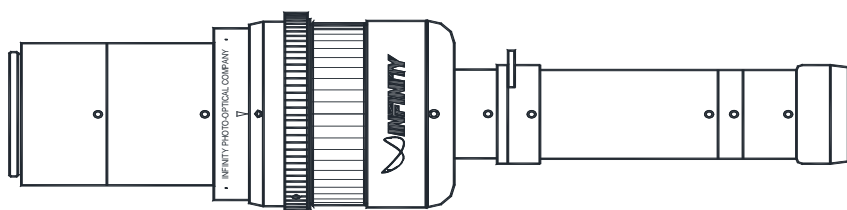

LENGTH: 232mm [9.13"] **SFX-3**

WEIGHT: 720.1g [25.4oz.]

InfiniProbe TS-160 ROBUSTO-Lite

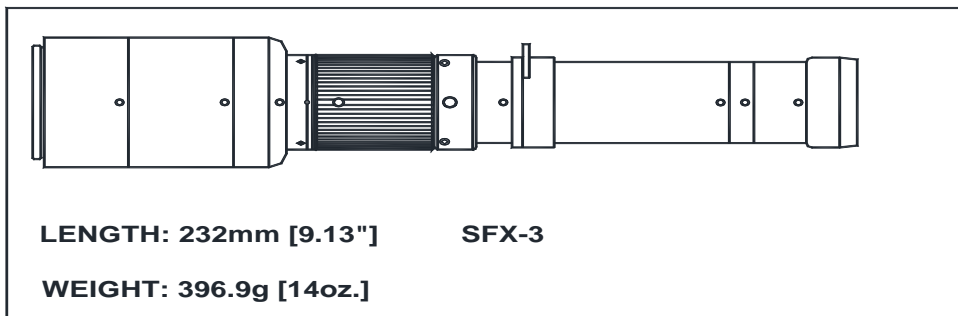
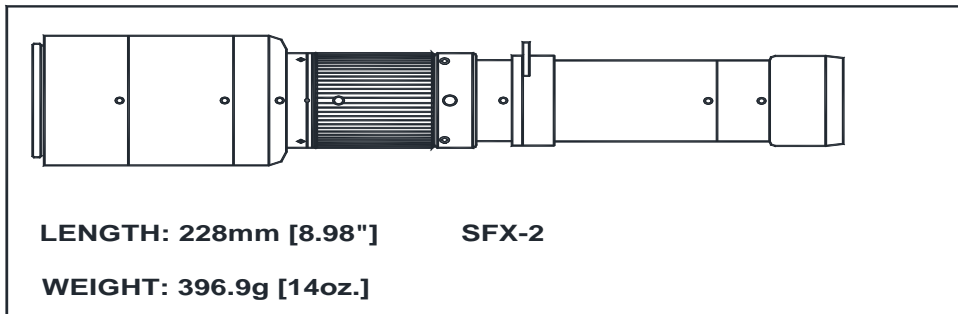
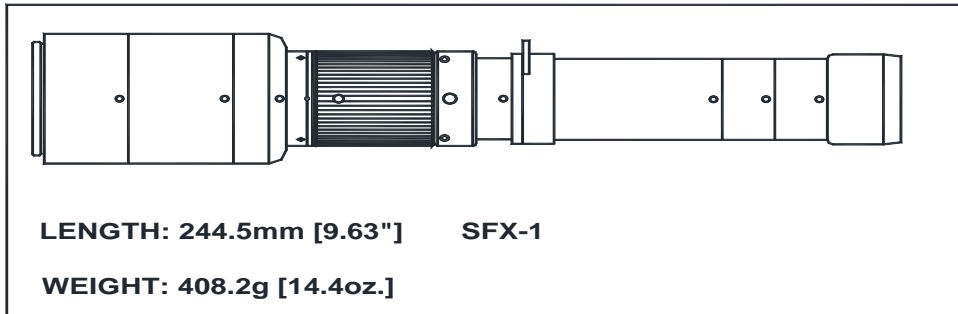

Illumination. The TS-160 provides the best results when the light is intense and highly-directed. For modeling and fixed illumination, fiber optic or LED sources are recommended. Nevertheless, the best way to capture high-resolution images is by using flash.

Mounting Options. The TS-160 can be mounted on standard tripods or jigs by means of an optional Large Clamp with 1/4-20 and two "outboard" M4 taps. Alternatively, it can be mounted on many brands of stereo microscope stands by optional adapters. Infinity makes a line of such adapters that are all 24mm long. The T24 tube can be removed and the selected Stereo Stand Adapter screwed on in place. Unlike many such adapters, Infinity's all become integral to the TS-160 itself.

Filter Holder. Removing all the T-tubes allows access to the Filter Holder Receptacle. Most 25mm diameter filters can be positioned there and locked in place by a Retaining Ring. M27 filters can also be attached. In this way, the TS-160 can be equipped with polarizing, color, neutral density or fluorescence filters.

InfiniLight™ Adapter Tubes. Presently there are two InfiniLight Tubes with front flanges to fit Canon and Nikon flash units onto the TS-160 Main Body. The InfiniLight combines with the TS-160 to make a very compact yet efficacious macro system with self-contained flash illumination.

The InfiniLight consists of a flanged T tube part that is 12mm thick another 12mm T tube attached to it, thereby making it possible to exchange the supplied T24 Tube so that the InfiniLight becomes integral to the TS-160. This also permits custom spacings (we will advise) for use with various cameras whose otherwise obstructive designs (*e.g.*, those with thick built-in handles) to be utilized on the TS-160.

C-mount Camera Use. The TS-160 lends its unique capabilities to high quality microscope cameras made by the major manufacturers. Most cameras used on laboratory-type microscopes are C-mount and usually have 2/3-in. or slightly larger sensors. These cameras often are supplied with useful software. Although the TS-160 is primarily designed to take advantage of formats as large as 35mm as provided by high-quality DSLRs, it can be used productively with microscope-type cameras as well. Please refer to the Infinity Photo-Optical website, www.infinity-usa.com for further details.

Care and Cleaning. Your InfiniProbe TS-160 should be treated as the fine instrument that it is. Care should be taken to keep dust and dirt off the external lens surfaces. The unit can be cleaned (metal parts only) with a cloth moistened with alcohol. The external optical surfaces should be cleaned only when necessary, and then, only by a soft cotton swab moistened by an approved optical glass cleaner. If you have further questions, please contact Infinity Photo-Optical Company or your authorized dealer.

Warranty. Details of the Warranty are contained on the Warranty Page (attached).

Video Formats

| Format | Factor | Diagram |
|--------|--------|---------|
| 1/4" | 0.5 | |
| 1/3" | 0.75 | |
| 1/2" | 1.0 | |
| 2/3" | 1.375 | |
| 1" | 2.0 | |

Unless otherwise noted all data is given for 1/2" camera sensors. For FOV or magnification in other sensor sizes use the factors listed. For example, a FOV of 25mm listed for a 1/3" camera would be $25 \times 0.75 = 18.75\text{mm}$.

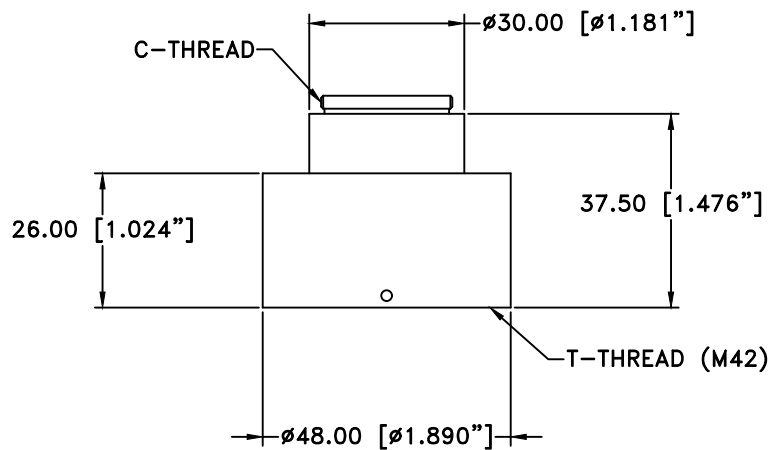

**770507
C-MOUNT VIDEO ADAPTER**

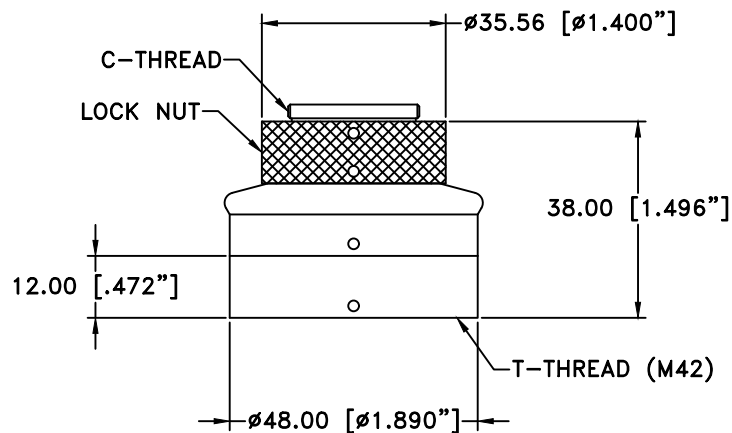

**770511
STANDARD ROTATABLE C-MOUNT**

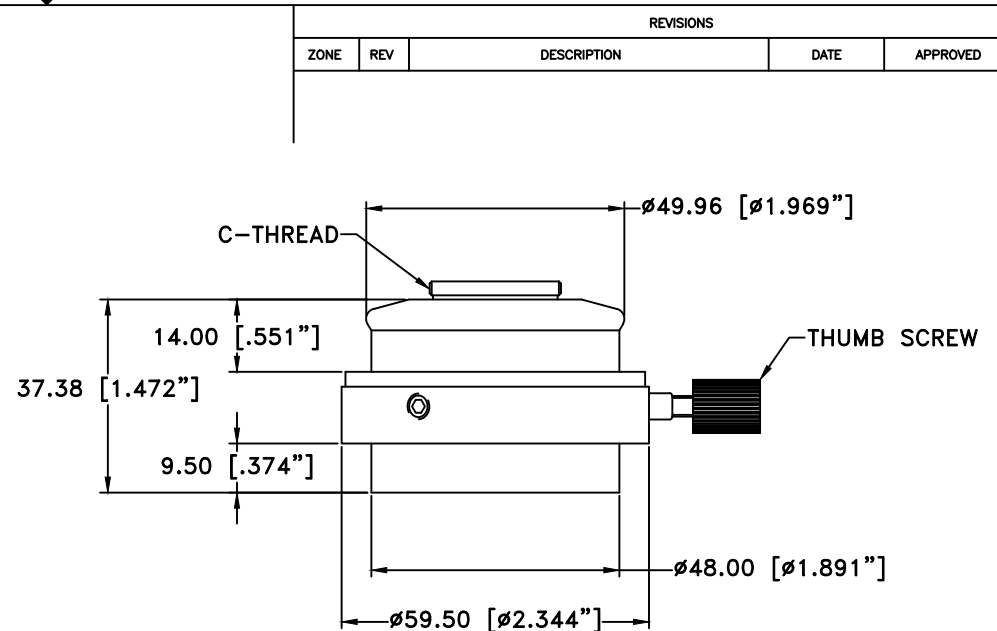

**770509
ORIENTABLE C-MOUNT
VIDEO ADAPTER**

| REVISIONS | | | | |
|-----------|-----|-------------|------|----------|
| ZONE | REV | DESCRIPTION | DATE | APPROVED |

**This drawing is for informational purposes only.
No other rights or privileges are granted or implied.**

THIS DRAWING IS THE PROPERTY OF THE INFINITY PHOTO-OPTICAL COMPANY AND IT MUST BE TREATED AS CONFIDENTIAL.
SURFACE FINISH: OUTSIDE DIAMETERS FINISH IS CRITICAL. BEAD BLAST INTERNAL RETAINERS
ALL DIMS. ARE IN mm [INCH].
DIM'S. ARE AFTER ANODIZING
TOL. DIAMETERS: ±0.025 [±0.001"]
OTHERS: ±0.102 [±0.004"]
UNIFIED THREADS ARE CLASS 2
METRIC THREADS ARE MEDIUM FIT
BREAK ALL SHARP EDGES TO R0.25 [R0.010"]

INFINITY Photo-Optical Company
www.infinity-usa.com

C-MOUNT VIDEO ADAPTERS

| | | | | |
|-------------------|------------|----------|--------------|-------|
| Date: 10/30/17 MB | SIZE B | FSCM NO. | DWG NO. | REV - |
| Modified: | SCALE NONE | - | SHEET 1 OF 1 | |

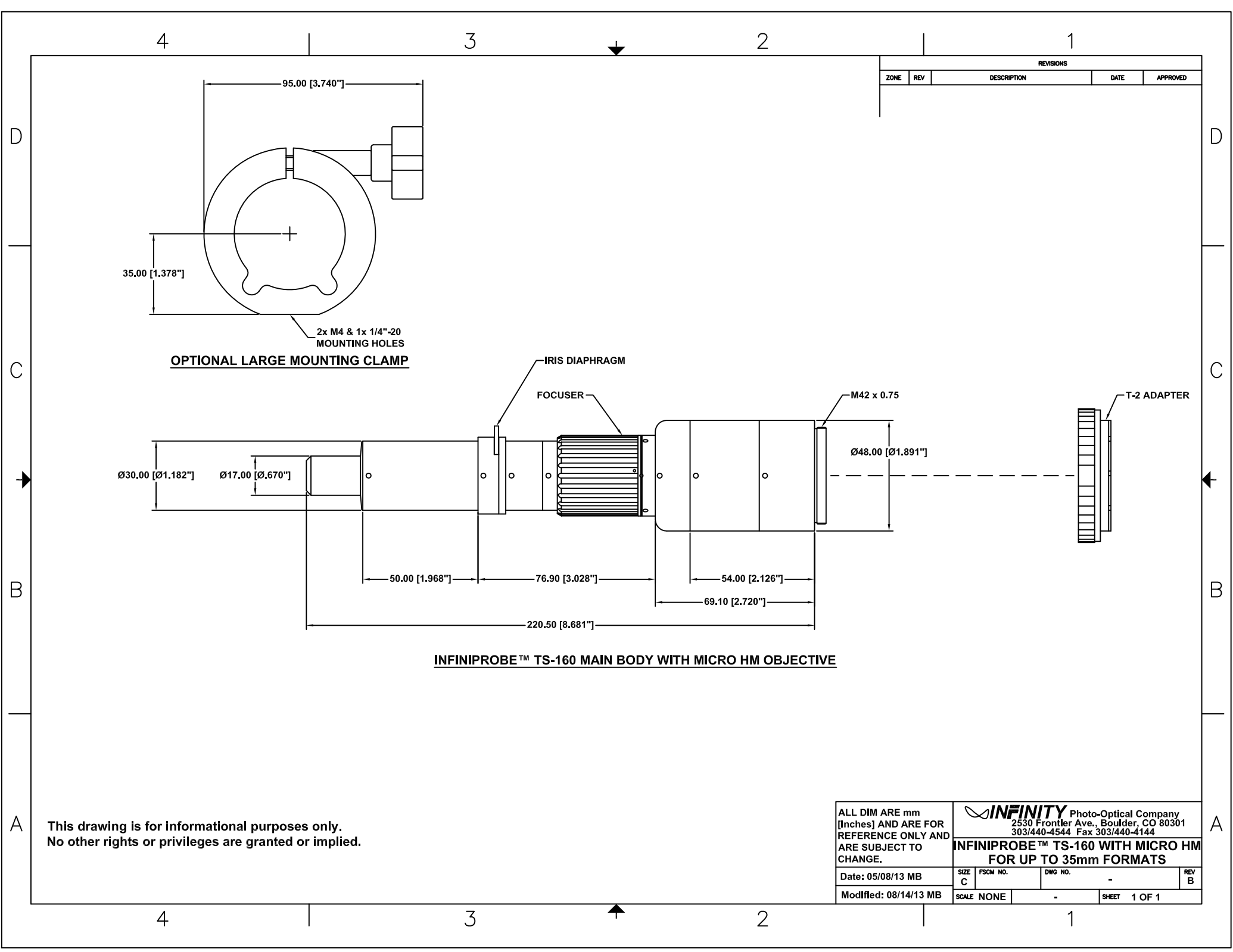

| REVISIONS | | | | |
|-----------|-----|-------------|------|----------|
| ZONE | REV | DESCRIPTION | DATE | APPROVED |
| | | | | |

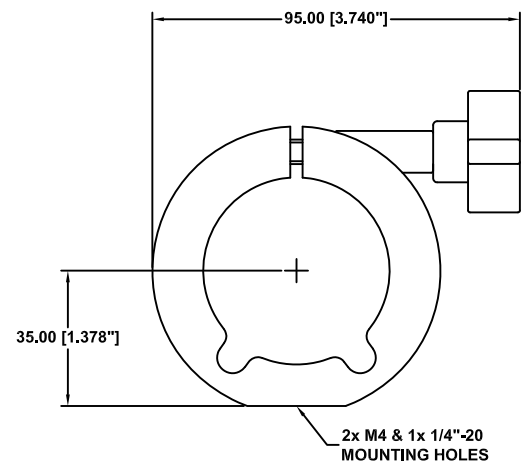

OPTIONAL LARGE MOUNTING CLAMP

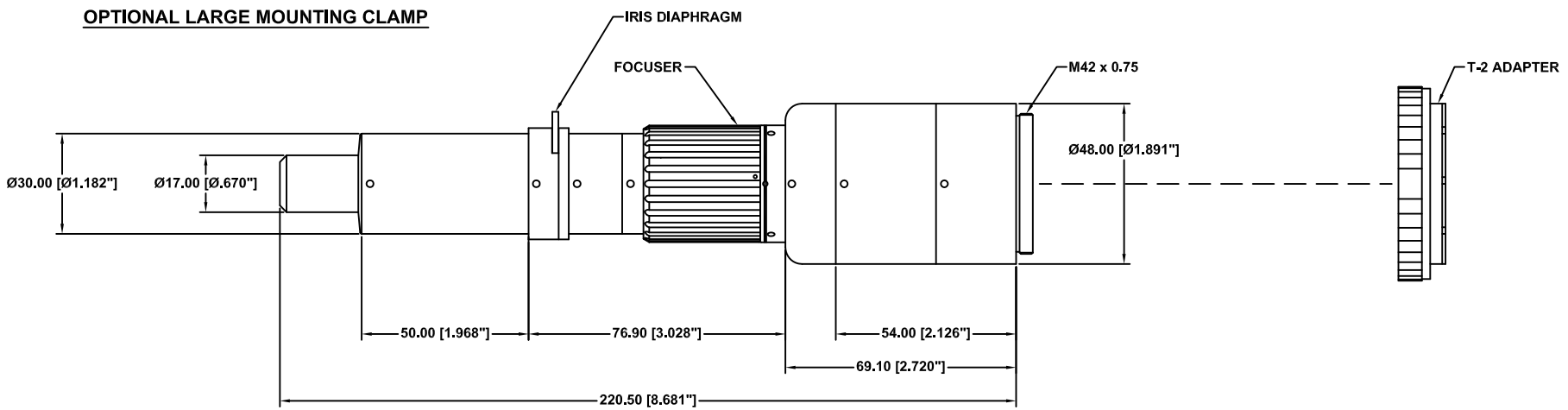

INFINIPROBE™ TS-160 MAIN BODY WITH MICRO HM OBJECTIVE

This drawing is for informational purposes only.
No other rights or privileges are granted or implied.

| | | | | |
|---|------------|--|-----------|--------------|
| ALL DIM ARE mm [Inches] AND ARE FOR REFERENCE ONLY AND ARE SUBJECT TO CHANGE. | | INFINITY Photo-Optical Company 2530 Frontler Ave., Boulder, CO 80301 303/440-4544 Fax 303/440-4144 | | |
| Date: 05/08/13 MB | SIZE C | FSCM NO. | DWG NO. - | REV B |
| Modified: 08/14/13 MB | SCALE NONE | - | | SHEET 1 OF 1 |

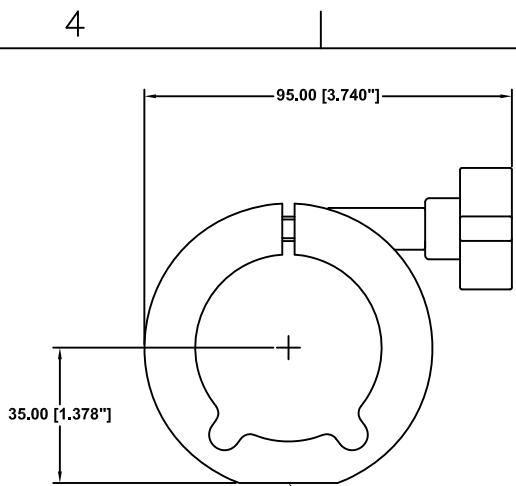

2x M4 & 1x 1/4"-20 MOUNTING HOLES
OPTIONAL LARGE MOUNTING CLAMP

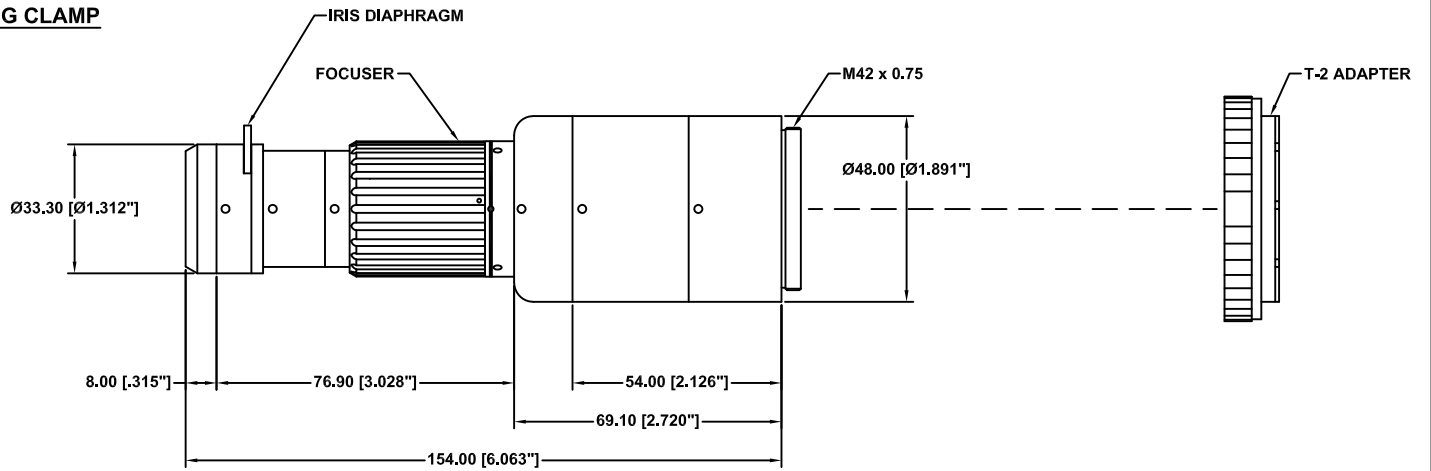

INFINIPROBE™ TS-160 MAIN BODY WITH MACRO OBJECTIVE

| REVISIONS | | | | |
|-----------|-----|-------------|------|----------|
| ZONE | REV | DESCRIPTION | DATE | APPROVED |
| | | | | |

This drawing is for informational purposes only.
 No other rights or privileges are granted or implied.

| | | | | |
|---|------------|--|-----------|--------------|
| ALL DIM ARE mm [Inches] AND ARE FOR REFERENCE ONLY AND ARE SUBJECT TO CHANGE. | | INFINITY Photo-Optical Company 2530 Frontler Ave., Boulder, CO 80301 303/440-4544 Fax 303/440-4144 | | |
| Date: 06/26/13 MB | SIZE C | FSCM NO. | DWG NO. - | REV B |
| Modified: 08/14/13 MB | SCALE NONE | - | | SHEET 1 OF 1 |

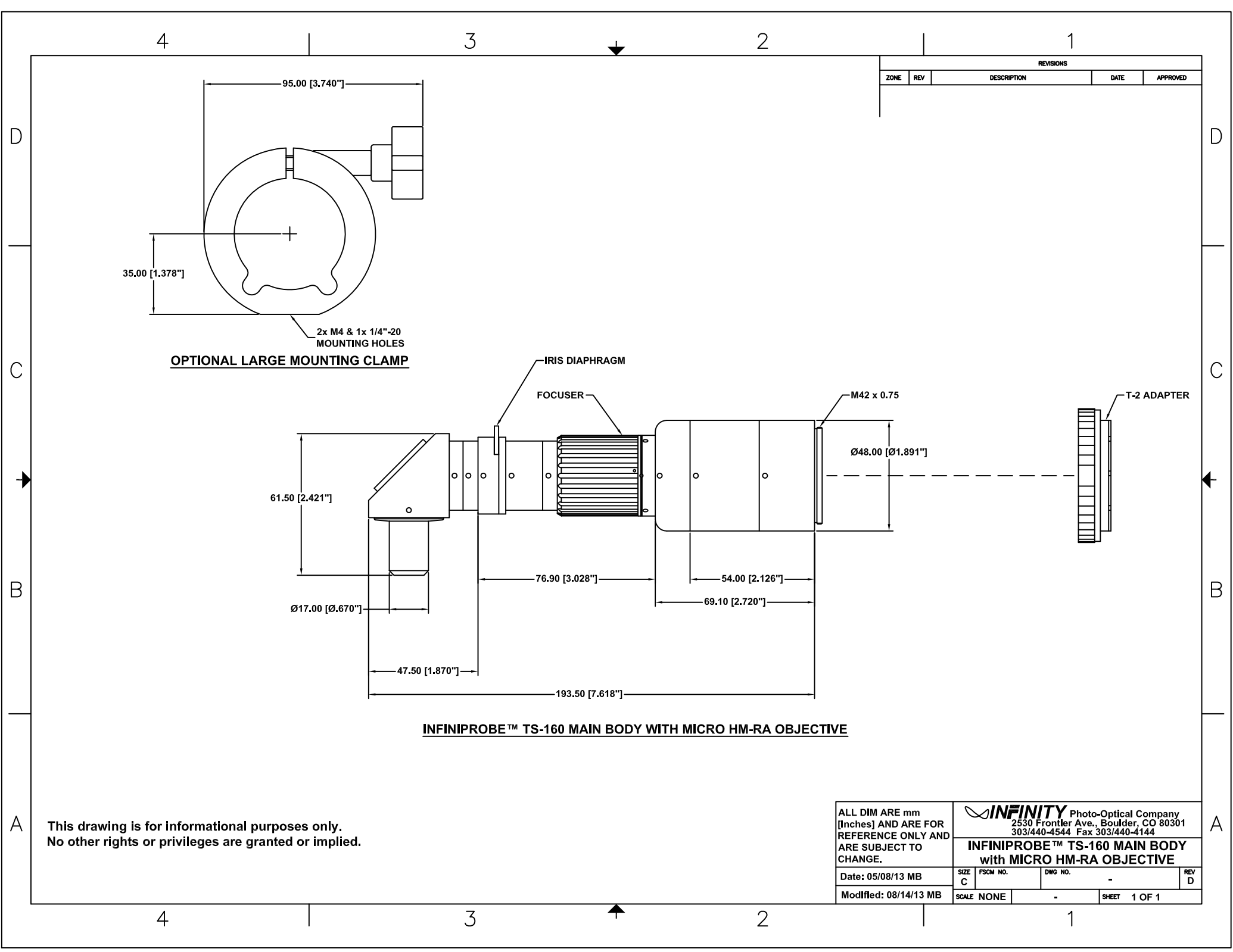

| REVISIONS | | | | |
|-----------|-----|-------------|------|----------|
| ZONE | REV | DESCRIPTION | DATE | APPROVED |
| | | | | |

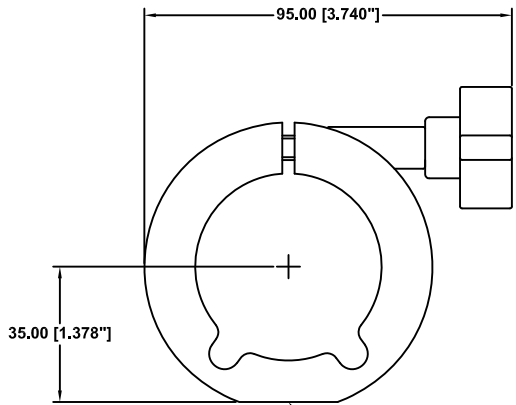

2x M4 & 1x 1/4"-20 MOUNTING HOLES
OPTIONAL LARGE MOUNTING CLAMP

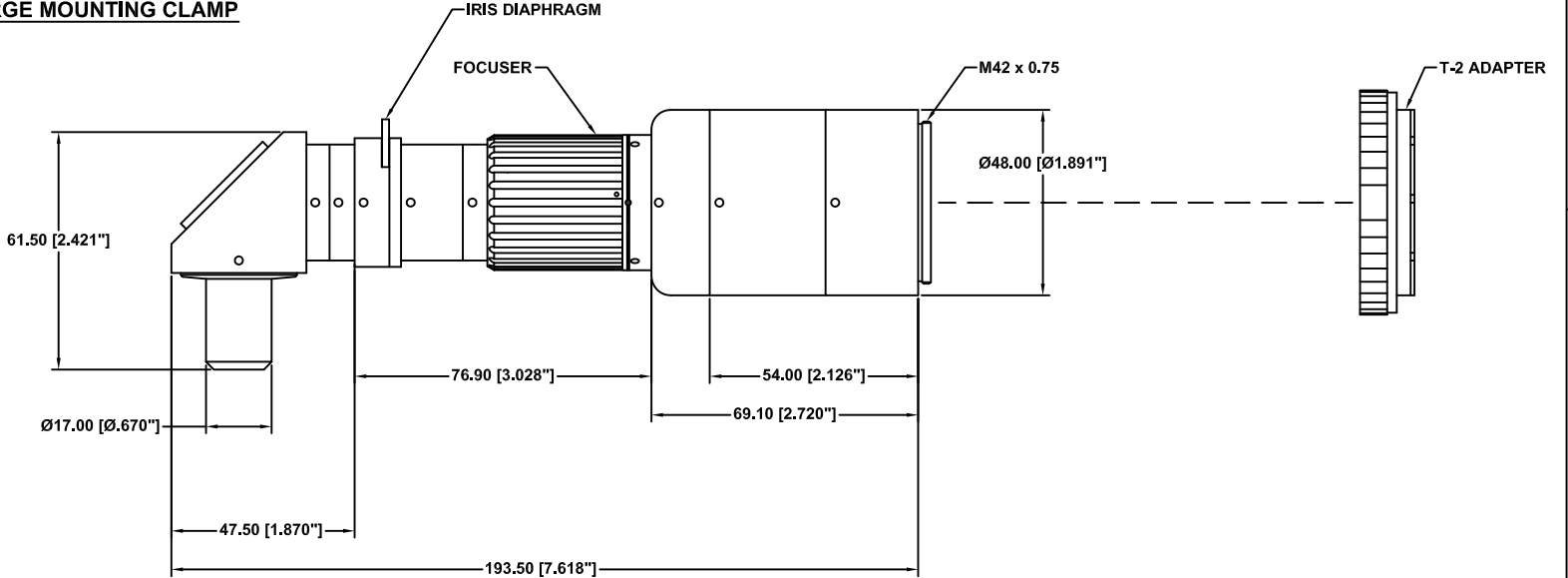

INFINIPROBE™ TS-160 MAIN BODY WITH MICRO HM-RA OBJECTIVE

This drawing is for informational purposes only.
 No other rights or privileges are granted or implied.

| | | | | | | | | | |
|---|--|--|--|--|--|----------|---------|-------|--------|
| ALL DIM ARE mm [Inches] AND ARE FOR REFERENCE ONLY AND ARE SUBJECT TO CHANGE. | | | | | INFINITY Photo-Optical Company 2530 Frontler Ave., Boulder, CO 80301 303/440-4544 Fax 303/440-4144 | | | | |
| INFINIPROBE™ TS-160 MAIN BODY with MICRO HM-RA OBJECTIVE | | | | | SIZE | FSCM NO. | DWG NO. | REV | D |
| Date: 05/08/13 MB | | | | | C | | - | | |
| Modified: 08/14/13 MB | | | | | SCALE | NONE | - | SHEET | 1 OF 1 |

| REVISIONS | | | | |
|-----------|-----|-------------|------|----------|
| ZONE | REV | DESCRIPTION | DATE | APPROVED |
| | | | | |

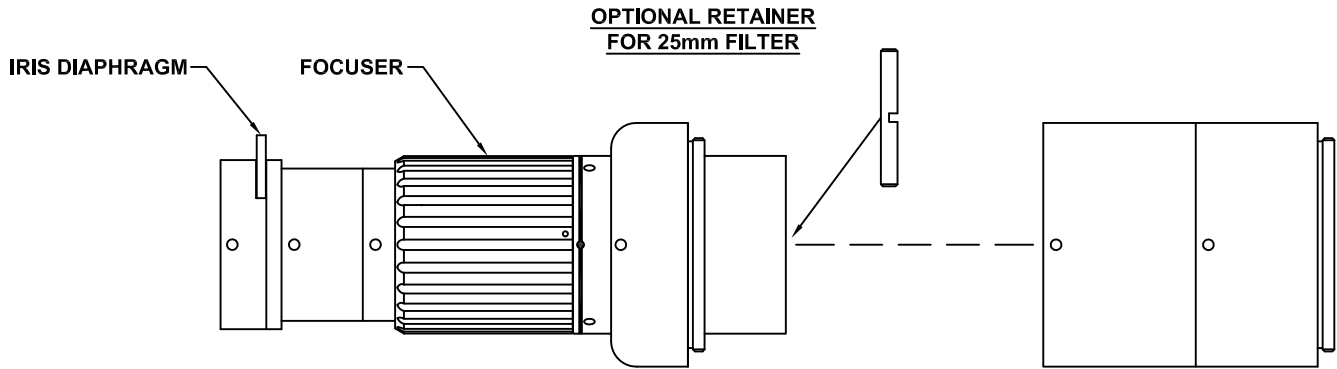

This drawing is for informational purposes only.
No other rights or privileges are granted or implied.

ALL DIM ARE mm
[inches] AND ARE FOR
REFERENCE ONLY AND
ARE SUBJECT TO
CHANGE.

INFINITY Photo-Optical Company
2530 Frontier Ave., Boulder, CO 80301
303/440-4544 Fax 303/440-4144

**INFINIPROBE™ TS-160 MAIN BODY
(FILTER INSERTION)**

| | | | | |
|-----------------------|------------|----------|--------------|----------|
| Date: 12/01/10 MB | SIZE B | FSCM NO. | DWG NO. - | REV B |
| Modified: 08/14/13 MB | SCALE NONE | - | SHEET 1 OF 1 | |

4

3

2

1

| REVISIONS | | | | |
|-----------|-----|-------------|------|----------|
| ZONE | REV | DESCRIPTION | DATE | APPROVED |
| | | | | |

D

D

C

C

B

B

A

A

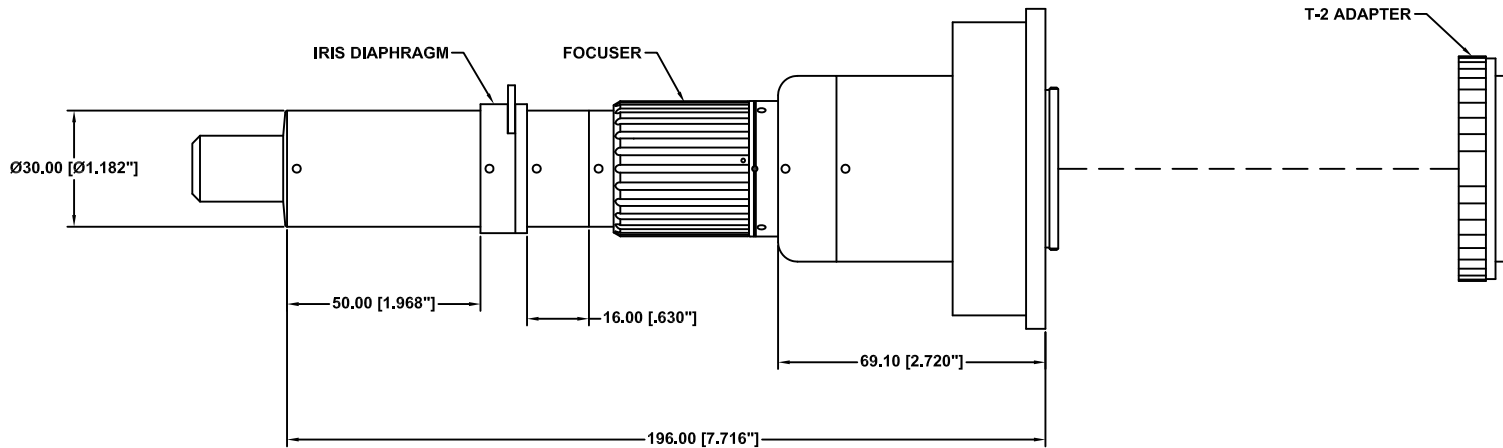
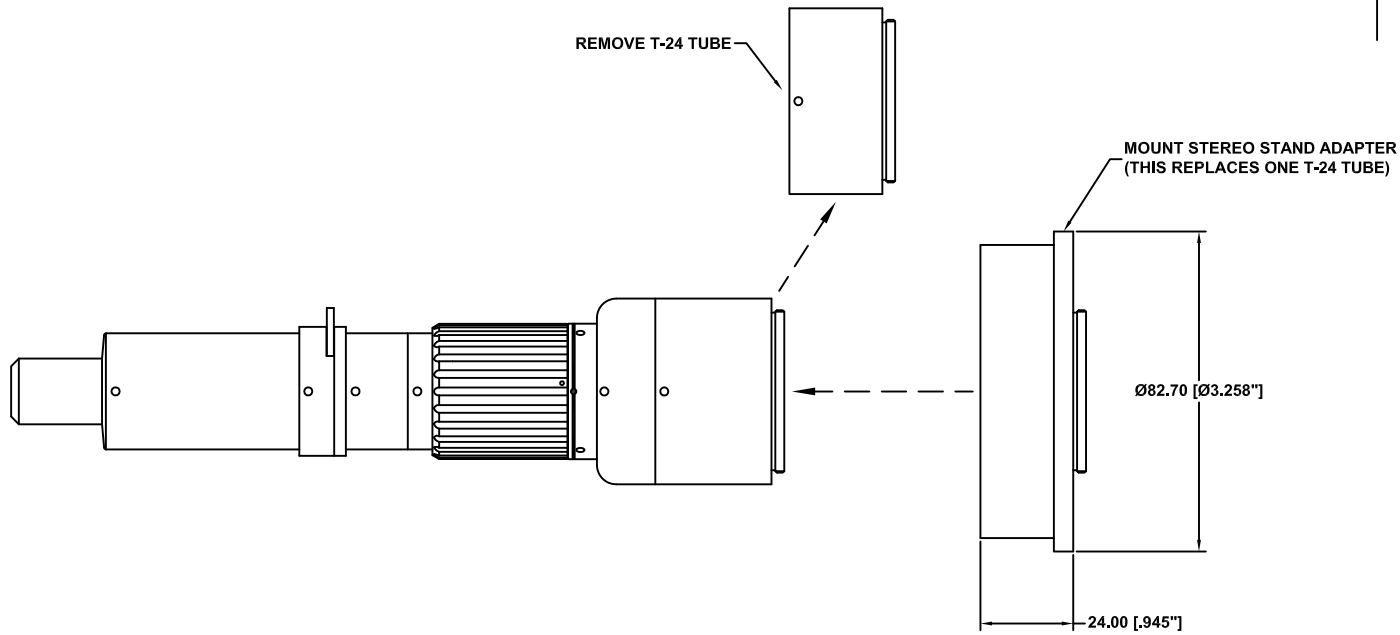

This drawing is for informational purposes only.
No other rights or privileges are granted or implied.

ALL DIM ARE mm
[Inches] AND ARE FOR
REFERENCE ONLY AND
ARE SUBJECT TO
CHANGE.

INFINITY Photo-Optical Company
2530 Frontier Ave., Boulder, CO 80301
303/440-4544 Fax 303/440-4144

**INFINIPROBE™ TS-160 W/MICRO HM
OBJ. AND STEREO STAND ADAPTER**

Date: 06/05/13 MB

SIZE C FSCM NO.

DWG NO. - REV B

Modified: 12/18/13 MB

SCALE NONE

SHEET 1 OF 1

4

3

2

1

4

3

2

1

| REVISIONS | | | | |
|-----------|-----|-------------|------|----------|
| ZONE | REV | DESCRIPTION | DATE | APPROVED |
| | | | | |

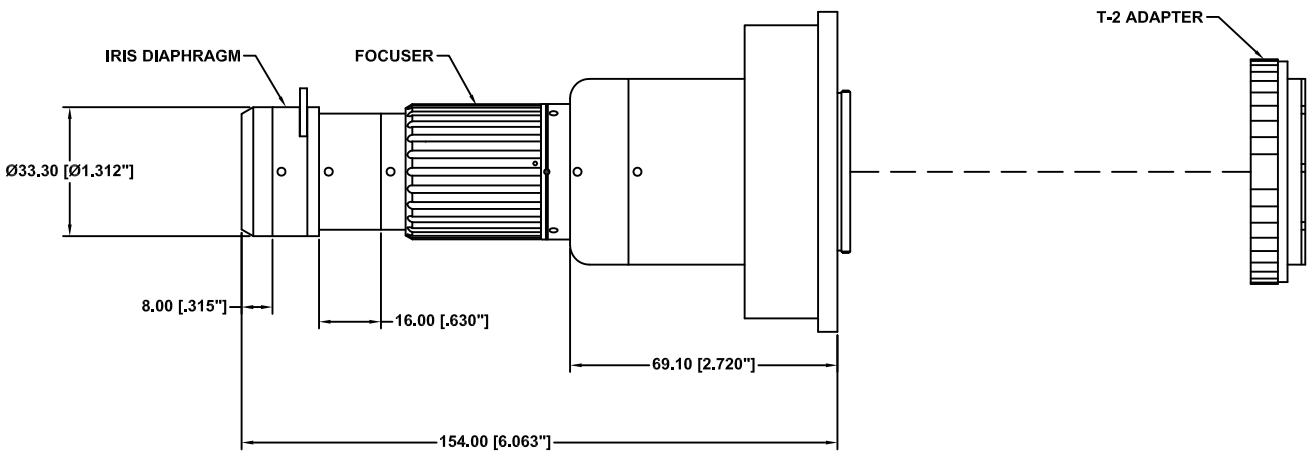
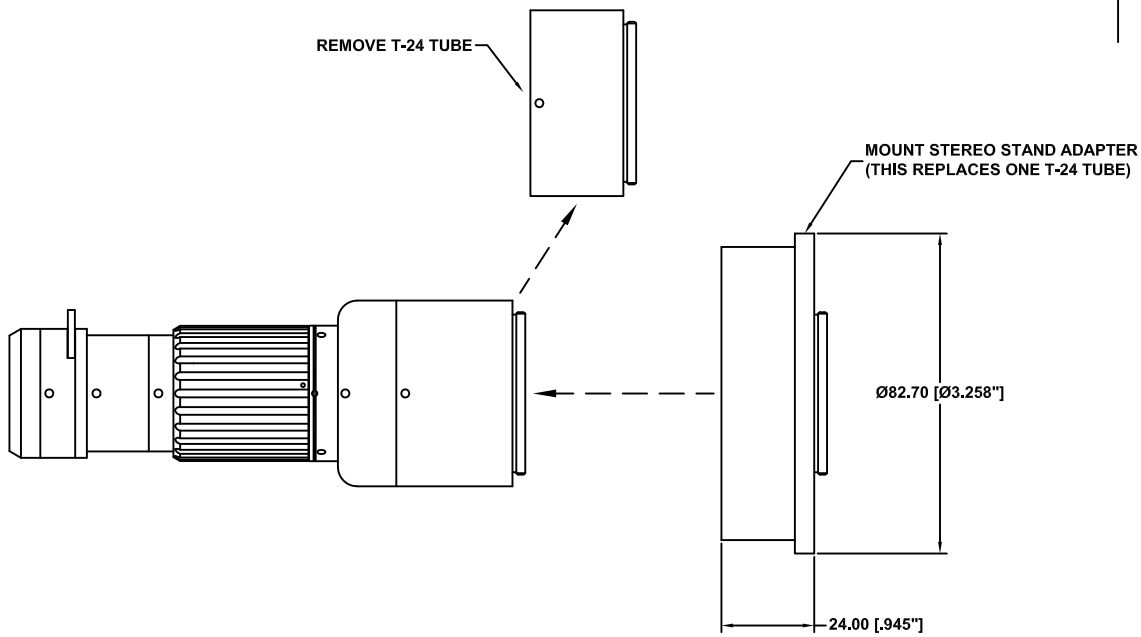

This drawing is for informational purposes only.
No other rights or privileges are granted or implied.

| | | | | |
|--|--|--|---------------------|------------------|
| <p>ALL DIM ARE mm [Inches] AND ARE FOR REFERENCE ONLY AND ARE SUBJECT TO CHANGE.</p> | | <p>INFINITY Photo-Optical Company 2530 Frontler Ave., Boulder, CO 80301 303/440-4544 Fax 303/440-4144</p> | | |
| <p>Date: 06/26/13 MB</p> | | <p>SIZE C</p> | <p>FSCM NO.</p> | <p>DWG NO. -</p> |
| <p>Modified: 12/18/13 MB</p> | | <p>SCALE NONE</p> | <p>SHEET 1 OF 1</p> | <p>REV B</p> |

4

3

2

1

| REVISIONS | | | | |
|-----------|-----|-------------|------|----------|
| ZONE | REV | DESCRIPTION | DATE | APPROVED |
| | | | | |

D
C
B
A

D
C
B
A

4

3

2

1

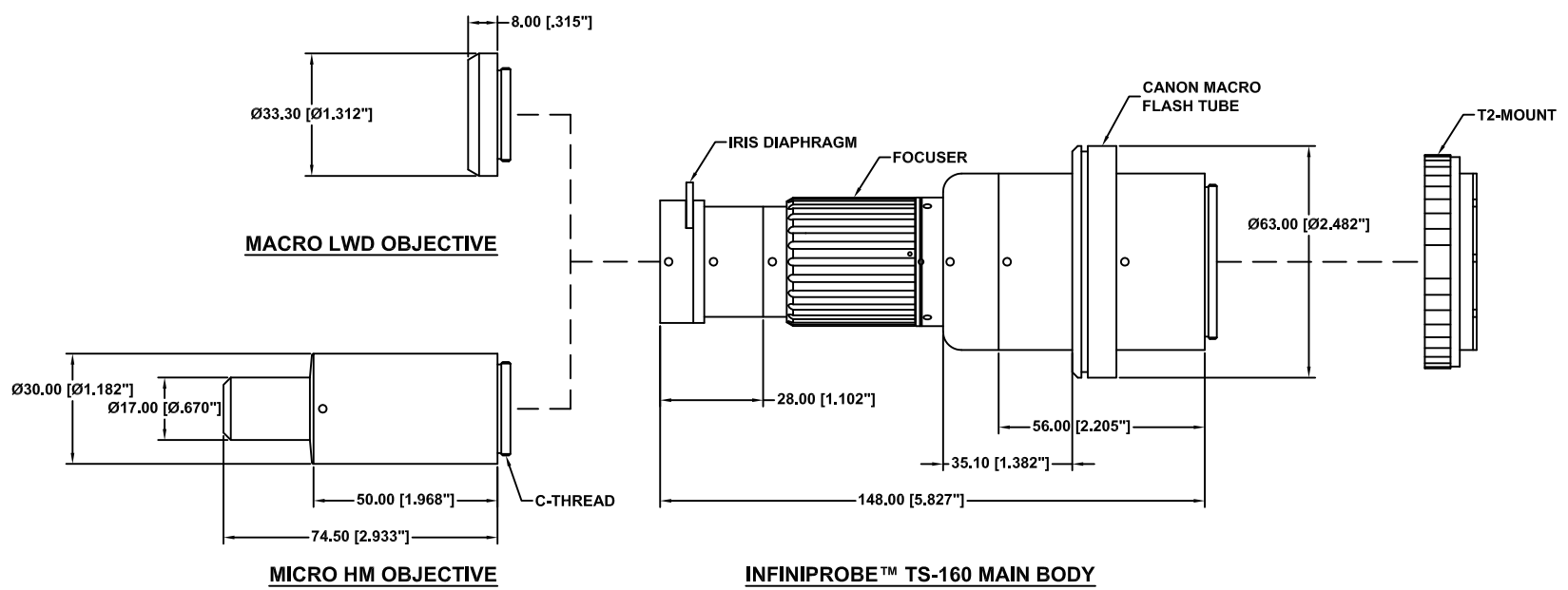

This drawing is for informational purposes only.
No other rights or privileges are granted or implied.

| | | | | |
|---|------------|--|-----------|--------------|
| ALL DIM ARE mm [Inches] AND ARE FOR REFERENCE ONLY AND ARE SUBJECT TO CHANGE. | | INFINITY Photo-Optical Company 2530 Frontler Ave., Boulder, CO 80301 303/440-4544 Fax 303/440-4144 | | |
| Date: 07/17/13 MB | SIZE C | FSCM NO. | DWG NO. - | REV A |
| Modified: 04/21/15 MB | SCALE NONE | - | | SHEET 1 OF 1 |

4

3

2

1

4

3

2

1

| REVISIONS | | | | |
|-----------|-----|-------------|------|----------|
| ZONE | REV | DESCRIPTION | DATE | APPROVED |
| | | | | |

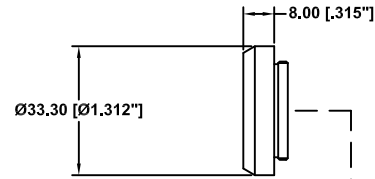

MACRO LWD OBJECTIVE

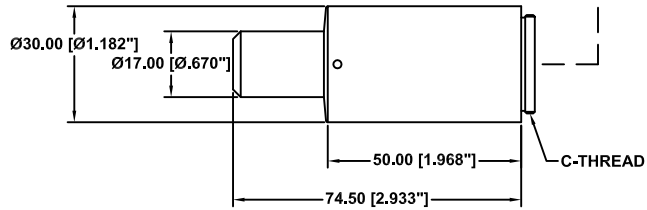

MICRO HM OBJECTIVE

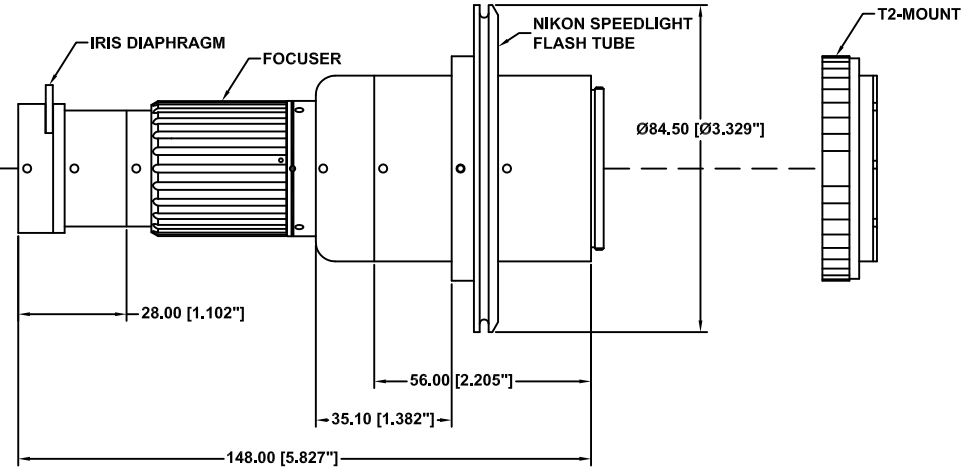

INFINIPROBE™ TS-160 MAIN BODY

This drawing is for informational purposes only.
No other rights or privileges are granted or implied.

ALL DIM ARE mm
[Inches] AND ARE FOR
REFERENCE ONLY AND
ARE SUBJECT TO
CHANGE.

Date: 04/21/15 MB

Modified:

INFINITY Photo-Optical Company
2530 Frontler Ave., Boulder, CO 80301
303/440-4544 Fax 303/440-4144

**INFINIPROBE™ TS-160 MAIN BODY
w/NIKON SPEEDLIGHT FLASH TUBE**

| | | | |
|------------|----------|--------------|----------|
| SIZE C | FSCM NO. | DWG NO. - | REV - |
| SCALE NONE | - | SHEET 1 OF 1 | |

4

3

2

1

D

C

B

A

D

C

B

A

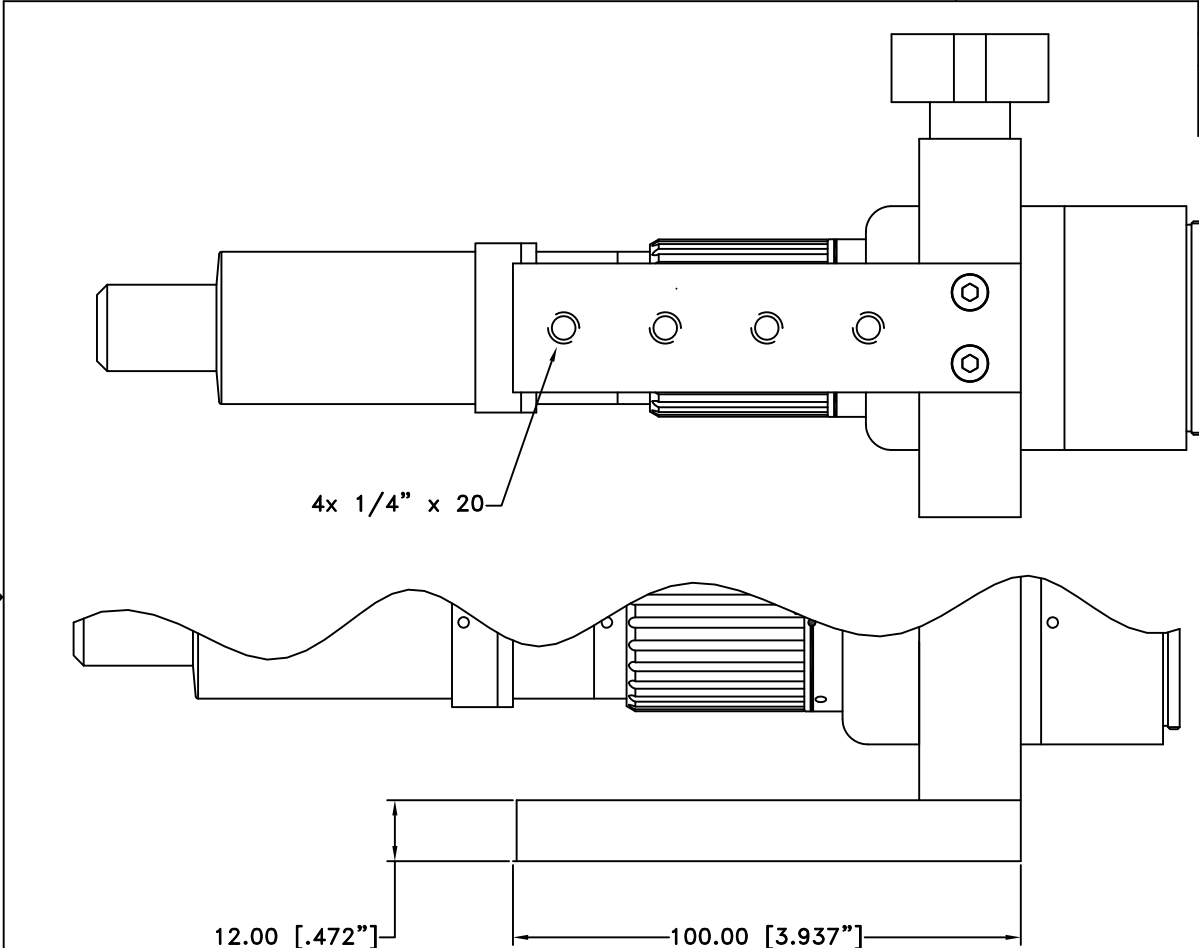

| REVISIONS | | | | |
|-----------|-----|-------------|------|----------|
| ZONE | REV | DESCRIPTION | DATE | APPROVED |

| | | | | |
|--|--|---|------------------------|--------------|
| | | | | |
| | |  INFINITY Photo-Optical Company 2530 Frontier Ave., Boulder, CO 80301 303/440-4544 Fax 303/440-4144 | | |
| INFINIPROBE TS-160 w/MOUNTING BAR | | | | |
| Date: 07/17/13 MB | | SIZE B | FSCM NO. | DWG NO. - |
| Modified: | | SCALE NONE | | REV - |
| | | | SHEET 1 OF 1 | |

NOTE:
 1. INFINIPROBE SHOWN WITH MICRO OBJECTIVE AND MOUNTING BAR.

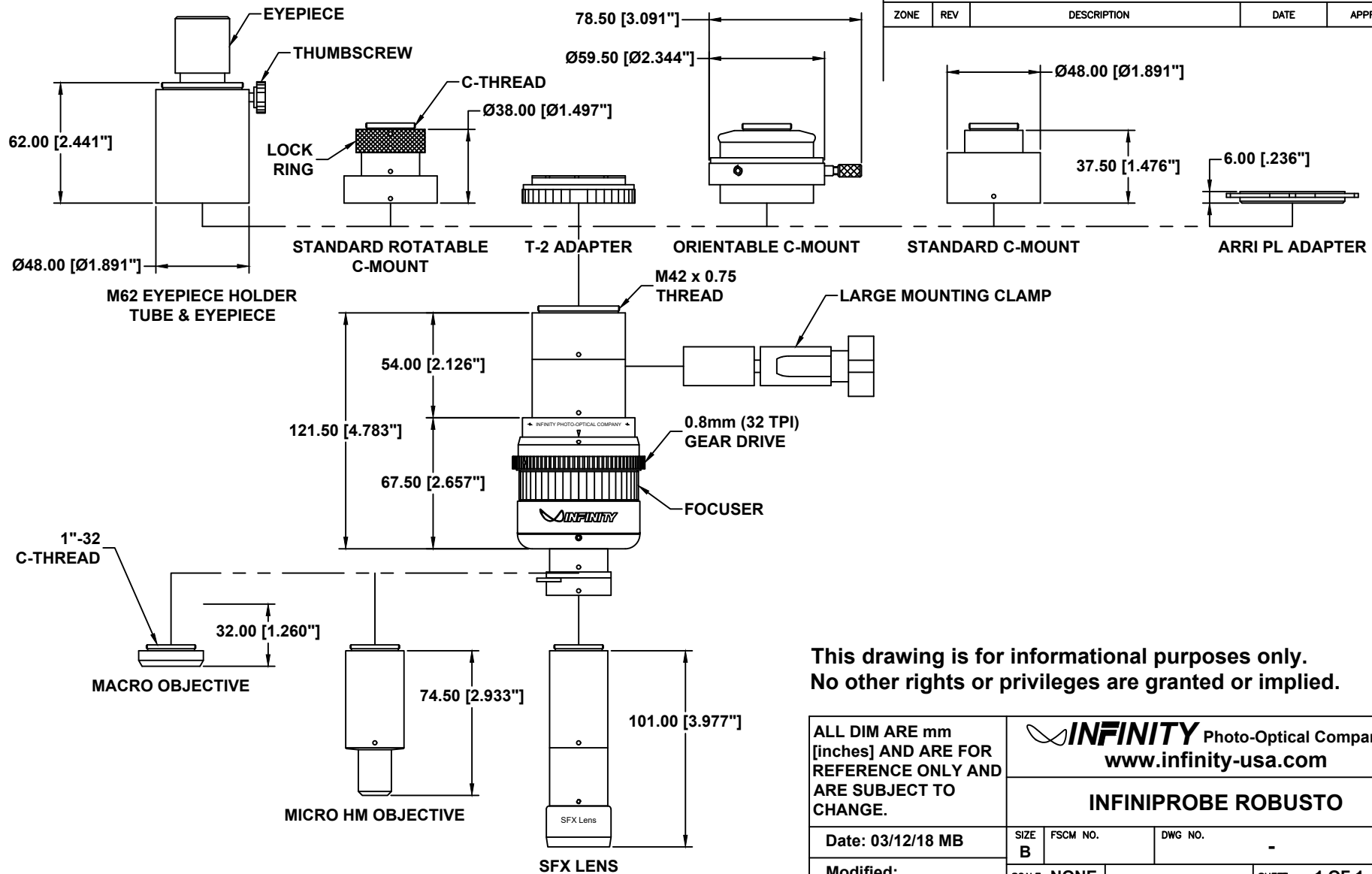

| REVISIONS | | | | |
|-----------|-----|-------------|------|----------|
| ZONE | REV | DESCRIPTION | DATE | APPROVED |

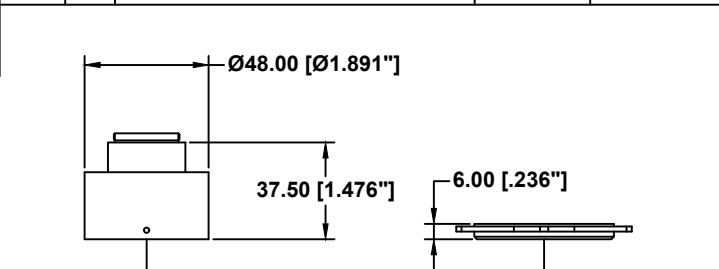

This drawing is for informational purposes only. No other rights or privileges are granted or implied.

| | | | | |
|---|------------|--|--------------|-------|
| ALL DIM ARE mm [inches] AND ARE FOR REFERENCE ONLY AND ARE SUBJECT TO CHANGE. | | INFINITY Photo-Optical Company www.infinity-usa.com | | |
| INFINIPROBE ROBUSTO | | | | |
| Date: 03/12/18 MB | SIZE B | FSCM NO. | DWG NO. - | REV - |
| Modified: | SCALE NONE | - | SHEET 1 OF 1 | |

INFINITY'S NEW TS-160 ROBUSTO CINE LENSES.

(shown with Arri-type PL mount)

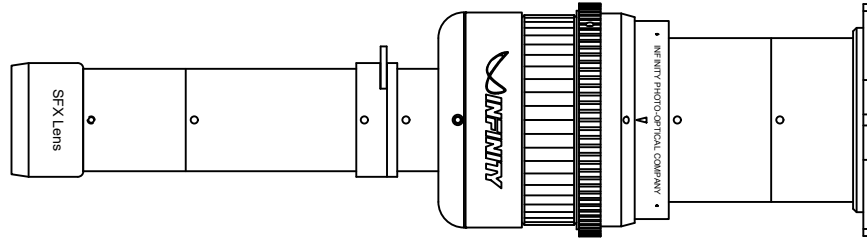

The new SFX Lenses maintain focus from near to infinity for photo and cine applications.

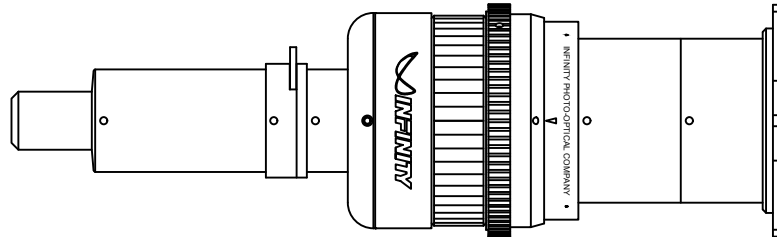

The Micro HM Objective provides 0-16x from infinity to 18mm.

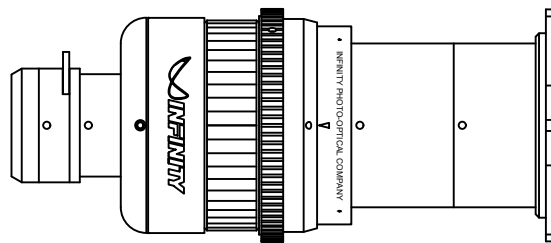

The Macro Objective provides 0-4x from infinity to 32mm.

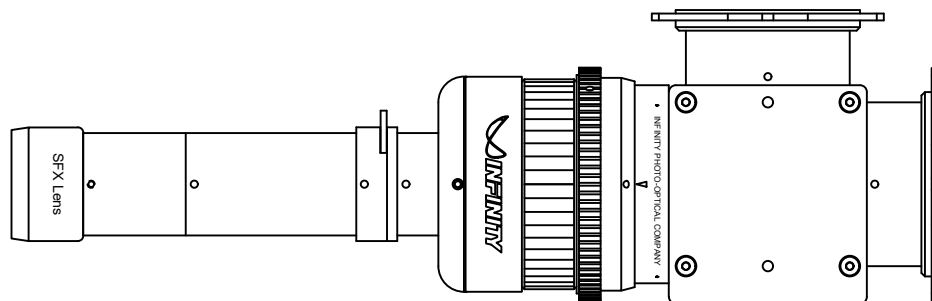

A Dual-port InfiniProbe shown with a Beamsplitter Cube.

InfiniProbe™ TS-160 UNIVERSAL Macro/Micro Imaging System

MICRO HM OBJECTIVE DATA

| | | | | | | | | |
|---------------|-------|-------|-------|------|------|-------|-------|-------|
| WD mm | 18 | 20 | 21 | 24 | 28 | 48 | 85 | 155 |
| Mag | 16.00 | 12.00 | 10.00 | 5.00 | 4.00 | 2.00 | 1.00 | 0.50 |
| FOV mm | 2.25 | 3.00 | 3.60 | 7.20 | 9.00 | 18.00 | 36.00 | 72.00 |

FOV based on 35mm format (36mm horizontally).

For formats other than 35mm: Divide magnification into the sensor's horizontal dimension.

For example, 23x23mm Sensor: $23\text{mm}/4x = 5.75\text{mm}$ FOV.

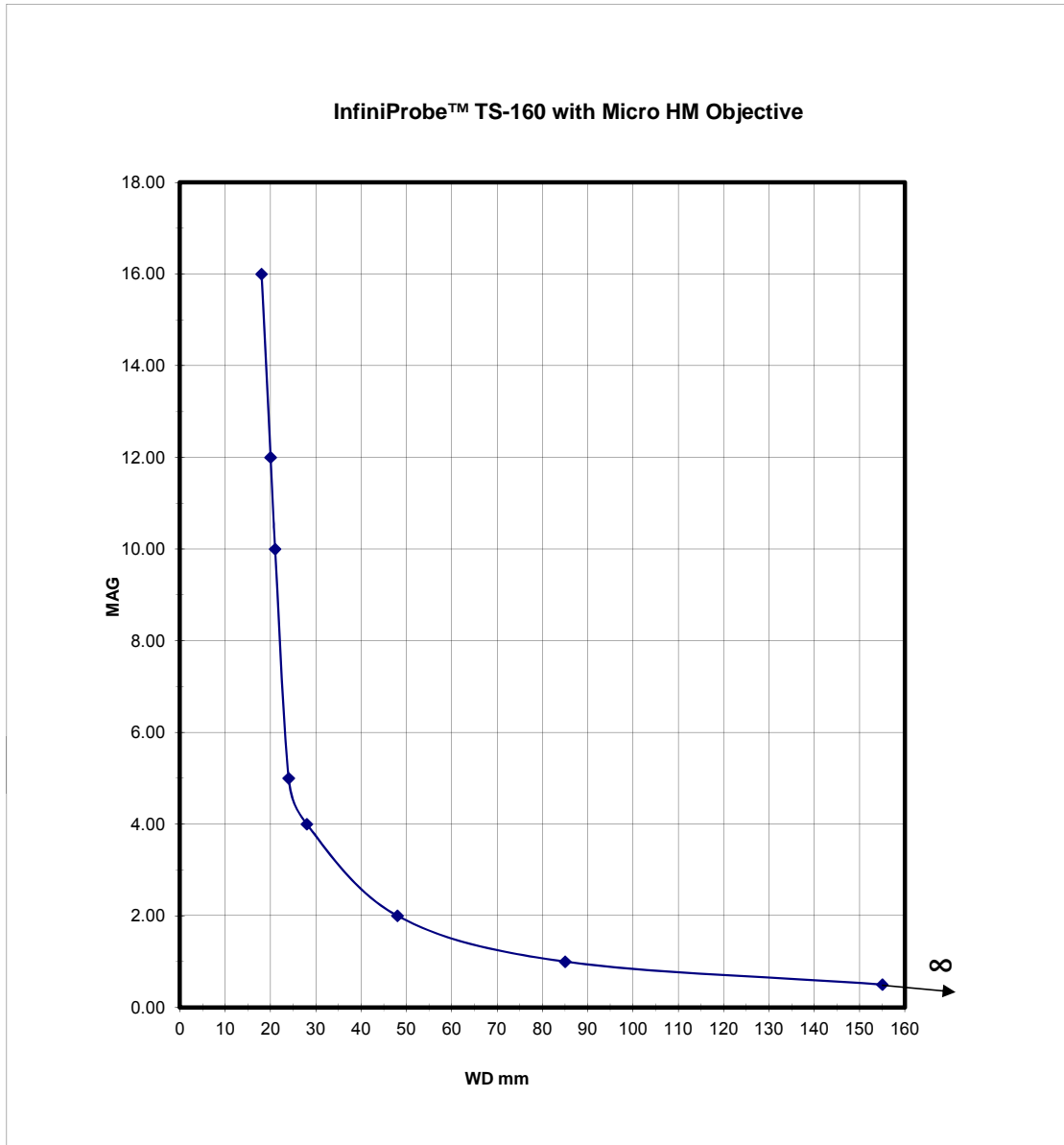

InfiniProbe™ TS-160 Macro/Micro Imaging System
MACRO OBJECTIVE DATA

| | | | | | | | | | |
|---------------|------|------|------|------|------|------|------|------|------|
| WD mm | 32 | 44 | 66 | 94 | 139 | 189 | 214 | 239 | 284 |
| Mag | 4.00 | 2.80 | 2.00 | 1.50 | 1.00 | 0.75 | 0.66 | 0.60 | 0.50 |
| FOV mm | 9.0 | 12.9 | 18.0 | 24.0 | 36.0 | 48.0 | 54.5 | 60.0 | 72.0 |

*FOV based on 35mm video format (36mm horizontally). See Video Format Page for all conversions.
 For formats other than 35mm: Divide magnification into the sensor's horizontal dimension.
 For example, 23x23mm Sensor: 23mm/4x = 5.75mm FOV.

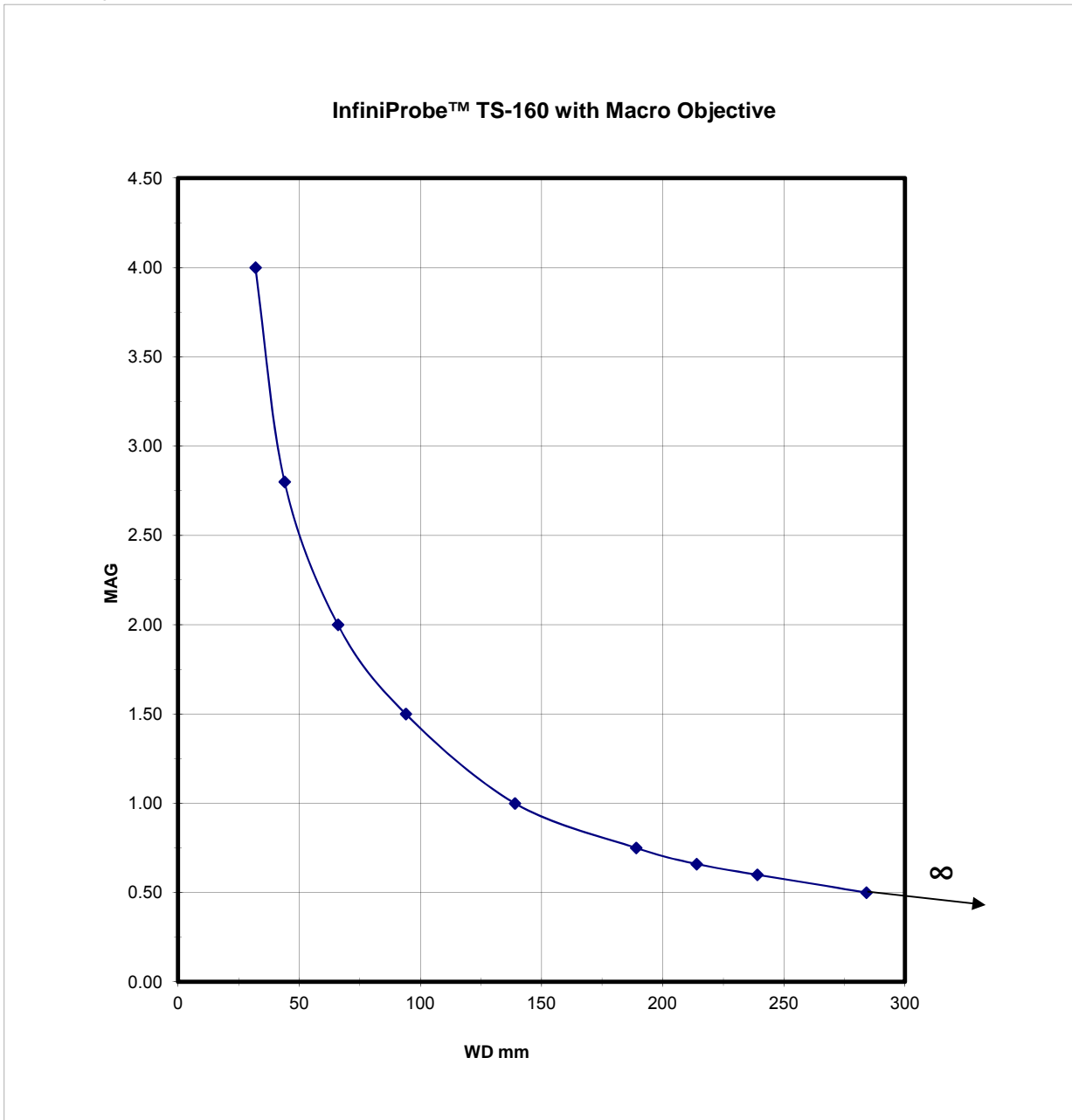

INFINITY PHOTO-OPTICAL COMPANY LIMITED WARRANTY

INFINITY PHOTO-OPTICAL COMPANY hereby warrants its products to be free from defects in workmanship or materials for the warranty period set forth below. INFINITY PHOTO-OPTICAL COMPANY, at its option, shall repair or replace the defective product without cost to the purchaser, and such repair or replacement shall be the full extent of this express limited warranty. INFINITY PHOTO-OPTICAL COMPANY shall not be liable for any other damages either direct or consequential.

This warranty is made to the original purchaser, and is effective only on new equipment purchased from INFINITY PHOTO-OPTICAL COMPANY, or a dealer authorized by INFINITY PHOTO-OPTICAL COMPANY to sell the product.

This warranty is valid only when the product is returned to the authorized dealer from whom it was purchased, or returned directly to INFINITY PHOTO-OPTICAL COMPANY, freight prepaid, with proof of date of purchase.

This warranty does not extend to any defect, malfunction or failure caused by misuse, abuse or the use of the product with equipment for which it may not have been intended. Any unauthorized repair voids this warranty.

The warranty period for all products manufactured by INFINITY PHOTO-OPTICAL COMPANY is five (5) years from date of original purchase. Parts or components made or sourced from other manufacturers shall be solely covered by that manufacturer's warranty.

The warranty contained herein is the only warranty made by INFINITY PHOTO-OPTICAL COMPANY. Any implied warranty of merchantability and/or fitness for a particular purpose is expressly excluded from this warranty. INFINITY PHOTO-OPTICAL COMPANY shall not be liable for any expense, loss, incidental or consequential damages which may arise in connection with the use of this equipment. Recovery under this warranty is limited to repair or replacement of the equipment as provided above.

INFINITY PHOTO-OPTICAL COMPANY reserves the right to modify designs, equipment and accessories without notice.